



PST21B Standard product AC-DC 600W Conduction cooled

▼ Features

- 85-264 Vac Input voltage ranges , PFC
- 1-3 isolated outputs
- 200*127* 40mm very low profile
- Industrial or ruggedized versions
- Active very low Inrush current
- Many output configurations available
- Conduction cooled 100°C baseplate

Safety IEC/EN 60950-1, RoHS lead-free-solder compliant



▼ Description

The PST21B, very compact and low profile 600W AC-DC power supply in chassis format, incorporates input filtering, input and output protections, very robust mechanical mounting and connection, conformal coating and MIL-STD options required in most of the severe environment for industrial, defense applications. The PSU provides high reliability thanks to the integration of Vicor Corp. modules, high efficiency, input-to-output isolation, soft start and **active very low inrush circuit**, overtemperature protection, input over/undervoltage lockout. The PSU is configurable with 1 to 3 outputs in many output voltages from 3V3 to 48Vdc, other outputs are even possible as semi-standard versions, they are continuously short-circuit proof. The 100°C baseplate allows operation in high temperature environment.

▼ Bloc diagram

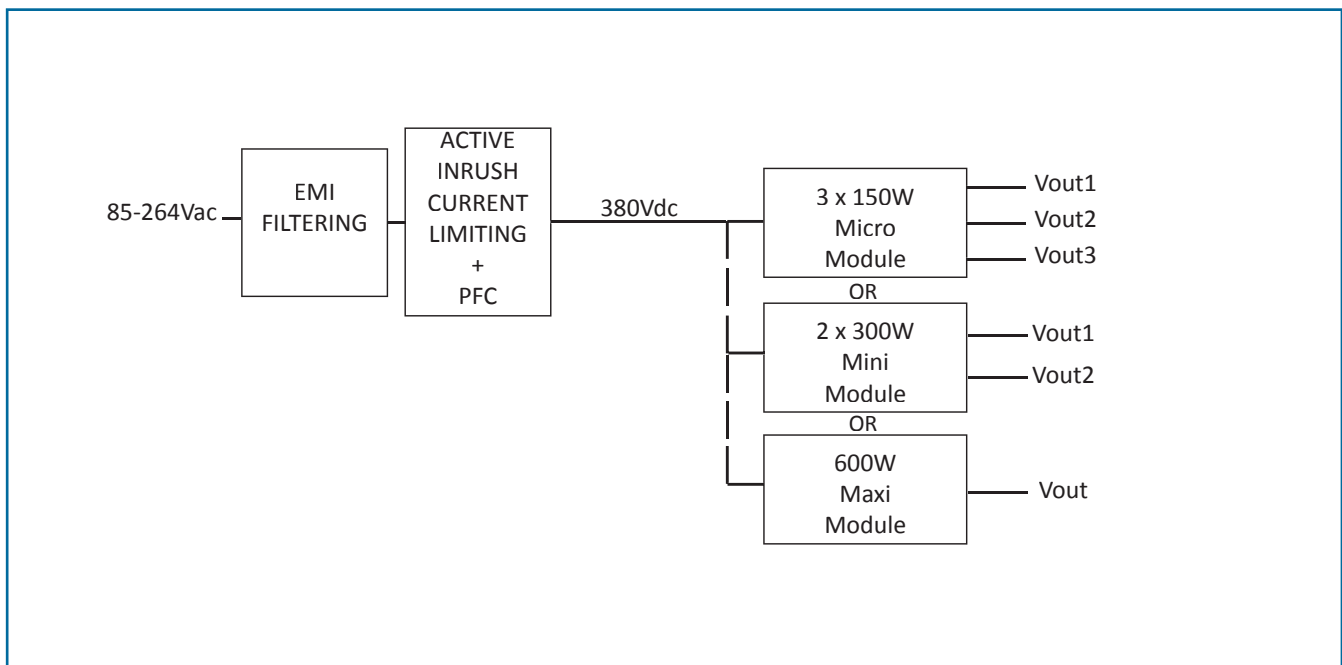



Options Description

MIL-STD ruggedized (-M)

Meet MIL-STD 461E CE102, MIL-STD 1399-300A, MIL-STD810E shock & vibrations. No Laboratory certification.

-40°C operation (-T)

The thermal grade of the Vicor the DC/DC converters used and other components are changed to comply with low ambient temperature.

Conformal coating (-V)

During manufacturing process , when V option is specified, components and pcb are covered with an acrylic coating to address high level of ambient humidity application.

Heatsink (-H, -H1)

-H: a 15 mm heatsink is mounted on the baseplate with longitudinal fins.

-H1: a 15 mm heatsink is mounted on the baseplate with transversal fins.

Input

Electrical Input Data

Input					Unit
Characteristics	Conditions	min	typ	max	
Operating input voltage		85		264	Vac
Operating input voltage		100		350	Vdc
Frequency		47	50	440	Hz
Power Factor	230Vac, 50Hz, Pnom.		0,96	0,98	
Input current	At Vin min			10	A
No-load input power	At Vin typ		8		W
Peak inrush current	Vin max			1	A
Start-up time				1	s

Input Fuse

A fuse mounted inside the psu protects against damages in case of a failure. The fuse is not user-accessible without opening the unit. In DC mode, reverse polarity at the input is protected and will not cause the fuse to blow .

Model	Fuse type	Rating	Reference
PST21B	Littlefuse	10A	0451010.MRL

Input Transient Protection

A VDR (Voltage Dependent Resistor) and a common mode input filter form an effective protection against input transients in severe environments.

Establishment time curve 230Vac 50Hz - PST21B-28600-MTV-IP

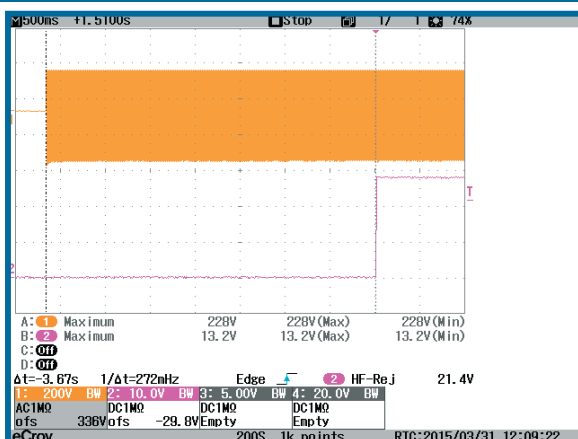

Efficiency curve - PST21B-28600-MTV-IP

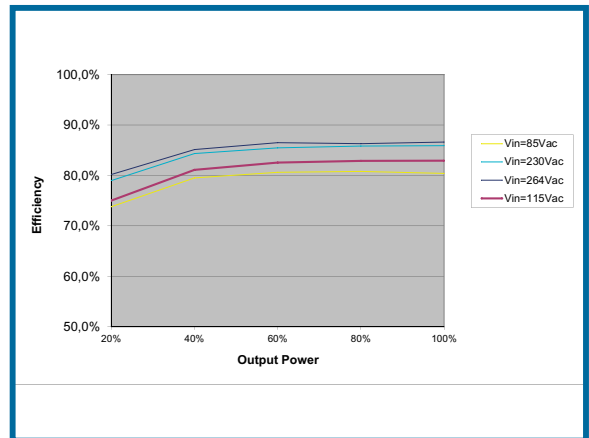

Power factor curve - PST21B-28600-MTV-IP

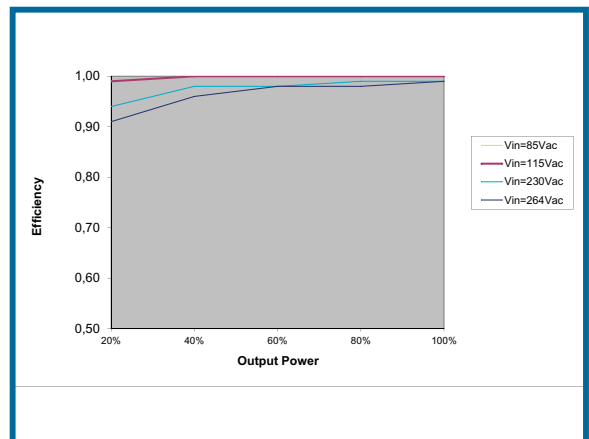

Establishment time curve 115Vac 50Hz - PST21B-28600-MTV-IP

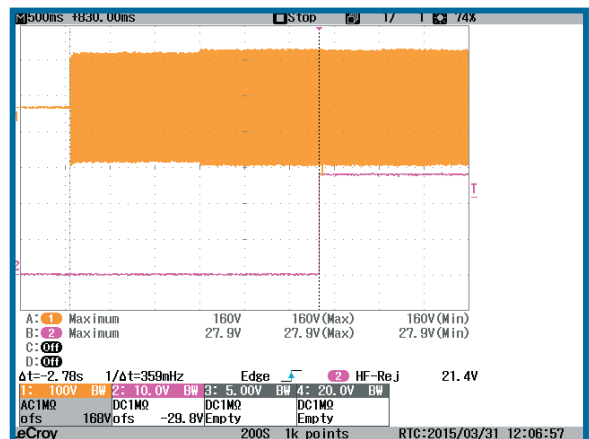



Electrical Output Data

General conditions : 25°C ambient. For each output voltage max power configuration.

PST21B can be equipped with one board of the models below (1 Maxi board / 1 Mini board / 1 Micro board)																							
Output		3V3			5V			12V			15V			24V			28V			48V			Unit
Characteristics	Conditions	min	typ	max	min	typ	max	min	typ	max	min	typ	max	min	typ	max	min	typ	max	min	typ	max	
Output voltage			3V3			5			12			15			24			28			48		V
Trim range	Factory set	3		3,6	4,5		5,5	10,8		13,2	13,5		16,5	21,6		26,2	25,2		30,8	43,2		51,8	V
Overvoltage protection				4,5		6,5				14,9		18,5			29,1			34				58	V
Output noise	20MHz		100			100			150			150			150			150				200	mVpp
Efficiency			75			83			85			84			85			83				84	%
Load Regulation	Vin nom.			1		1			0,5			0,5			0,4			0,4				0,4	%
Maxi Board (M)	includes 1 Maxi module below																						
Output current		0		80	0		80	0		50	0		40	0		25	0		21,5	0		12,5	A
Max. power				264			400			600			600			600			600			600	W
Output current limit			92	104		92	108		57,5	67,5		46	56		29	39		24	29		14	17	A
Mini Board (m)	includes up to two 2 Mini modules below																						
Output current		0		45	0		40	0		25	0		20	0		12,5	0		10,7	0		6,25	A
Max. power				150			200			300			300			300			300			300	W
Output current limit			54	64		46	52		29	35		23	26		14,5	17		12,5	14,5		7,2	8,2	A
Micro Board (μ)	includes up to 3 Micro modules below																						
Output current		0		22,7	0		20	0		12,5	0		10	0		6,25	0		5,3	0		3,1	A
Max. power				75			100			150			150			150			150			150	W
Output current limit			25	31		23	26		14,5	17		11	14		7,2	8,2		6,2	7		3,6	4,4	A

See "options and configurations" section for all the power possibilities.



Parallel operation & current share

Parallel operation is possible in the same unit or between different units for Miniboards, Maxiboards and dual Maxiboard with active current sharing through the PR signal. The outputs put in parallel **MUST** be exactly the same, all OUT+ connected together and all OUT- connected together when PR are linked (risk of damage otherwise).

Redundant Systems Operation

When systems require a very high level of reliability and should work normally in the event of a failure, N+1 redundancy is implemented where N is the number of converter to support power requirement. If one converter fails, the remaining ones still delivers the power to the loads.

Redundant operation requires external oring diodes.

Hold-up time

The psu provides internal hold-up time (see curve).

Output Current Limitation

All outputs are continuously protected against short-circuit by a constant current limitation (no foldback) with automatic recovery. See Page 2 for the value.

Thermal Considerations

When a converter is mounted in conduction cooled, the temperature measured on the baseplate should not exceed 100°C. When heatsink option is used in convection cooling and is operating at its nominal output power at the max. ambient temperature, the temperature measured on the heatsink should not exceed 100°C.

Thermal protection

A temperature protection (OTP) is integrated in each output module, disabling output when baseplate temperature exceeds 105°C (+/-5°C). The converter automatically restarts, when the temperature drops below 70°C. Nevertheless, exceeding the max operating temperature may cause failures of the converter.

Overvoltage protection

An OVP is incorporated on each output. All outputs are cut if an OVP is detected. This protection is latch style (Recovery after AC reset or inhibit).

Auxiliary Functions

Remote On/Off (INHIB)

An isolated INHIB signal disables corresponding output voltage when connected to RTN. - outputs inhibited : INH level LOW

Output Voltage Adjustment (ADJ)

Output can be adjusted 90-110 % Vnom. with the potentiometer at the output side or by an external voltage 0,6 to 1,25V max. referred to RTN.

Hold up time - PST21B-28600-MTV-IP

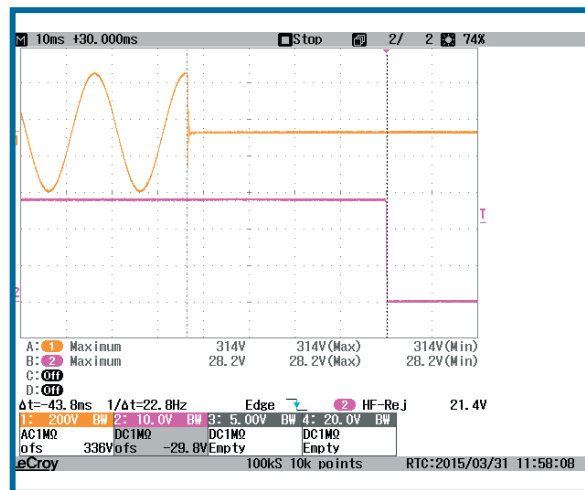

Inrush current at 115Vac - PST21B-28600-MTV-IP

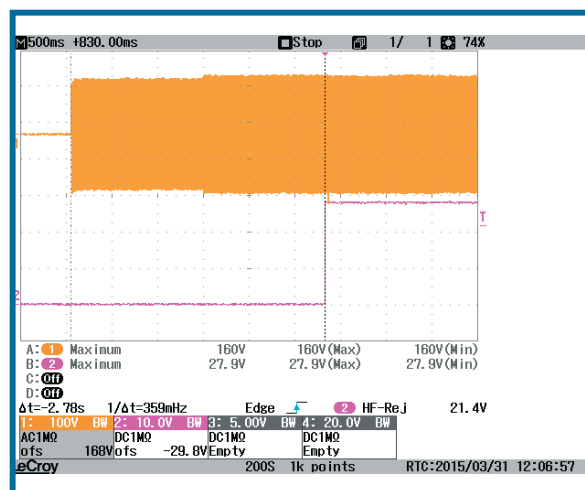

Inrush current at 230Vac - PST21B-28600-MTV-IP

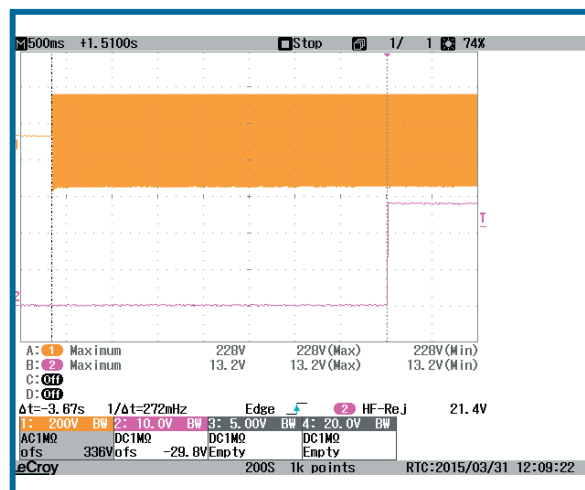



Remote Senses (+S -S)

This feature enables compensation of voltage drop across the connector contacts and the load lines. Remote Sense, max 0,5V per line compensation (If local sense, connect locally S+ to OUT+ and S- to OUT- of the corresponding output).

Output type	Total drop	Positive line drop
V1, V2	< 0.5V	< 0.25V

PowerGood & LED (Pgood+ Pgood-)

Collector isolated optocoupled signal referred to RTN, closed when all outputs voltages are OK. Led is also available for each output.

Auxiliary bias voltage (+5VAUX)

Auxiliary supply limited to 1mA. Referred to RTN

Paralleling signal (PR)

Parallel only identical outputs (voltage and power). Outputs in parallel will current share when their corresponding PR are connected together. When outputs are coming from different boards, RTN have to be connected together.

Waveforms

output noise - PST21B-28600-MTV-IP

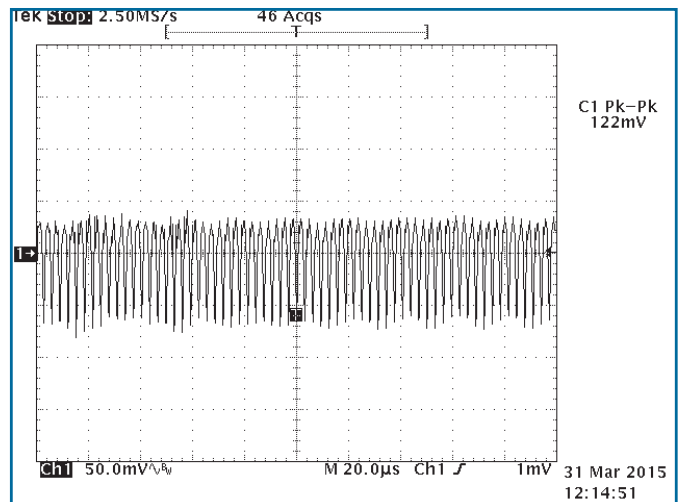

Derating - PST21B-28600-MTV-IP

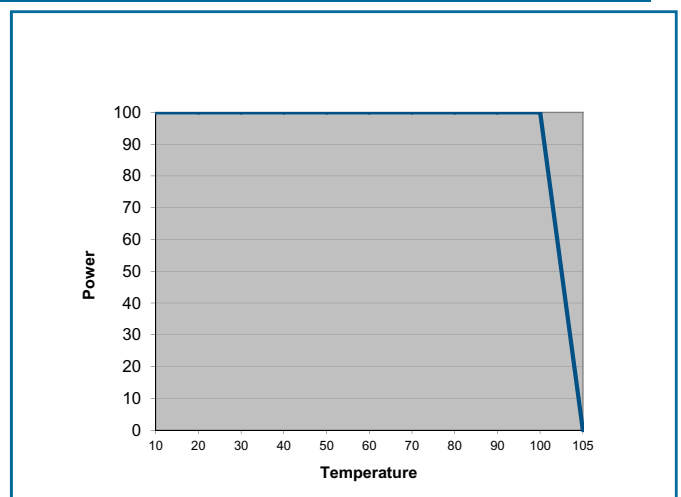



Electromagnetic

Electromagnetic Immunity

		Standard		Level	Value	Waveform	Source imped.	Test procedure	Mode	Criteria
Surges	Built to meet	EN 61000-4-5	DM	3	1KV	1,2 / 50 μ s	12 ohms		OP	B
			CM		2KV	1,2 / 50 μ s	12 ohms		OP	A
Electrostatic discharge (to case)	Built to meet	EN 6100-4-2		4	8000V	1 / 50 μ s	330 Ohms	10 pos., 10neg.	OP	B
Electrical fast transients/burst	Built to meet	EN 61000-4-4		4	4000V	5 / 50 μ s	50 ohms		OP	B

Note : Built to meet EN 61000-4 -3, -6, -11, Harmonics EN 61000-3-2, Flickers EN 61000-3-3

Electromagnetic Emissions

According to EN55022A IN 230Vac OUT 600V Neutral for PST21B-28600-MTV-IP

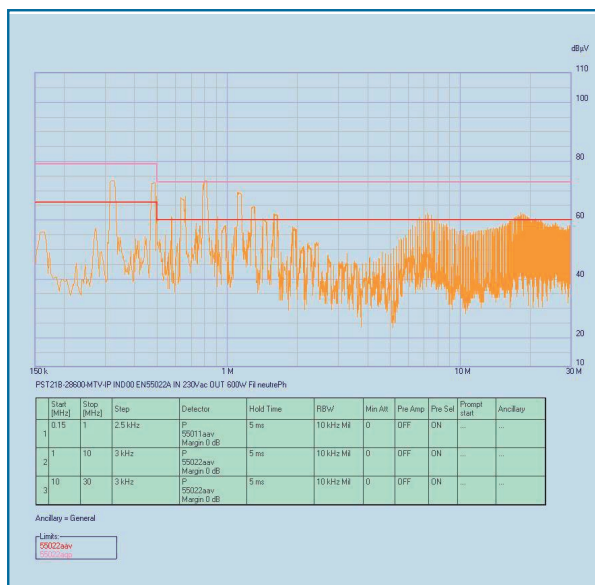

According to EN55022A IN 230Vac OUT 600V Phase for PST21B-28600-MTV-IP

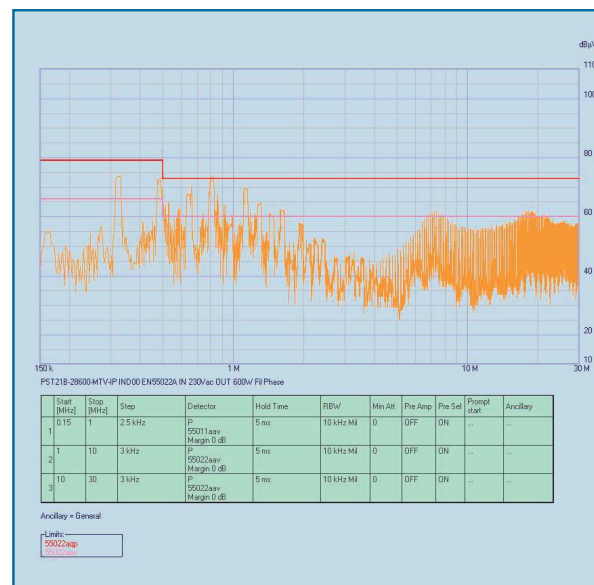

According to MIL-STD461E CE102 - 220V 600W Neutral for PST21B-28600-MTV-IP

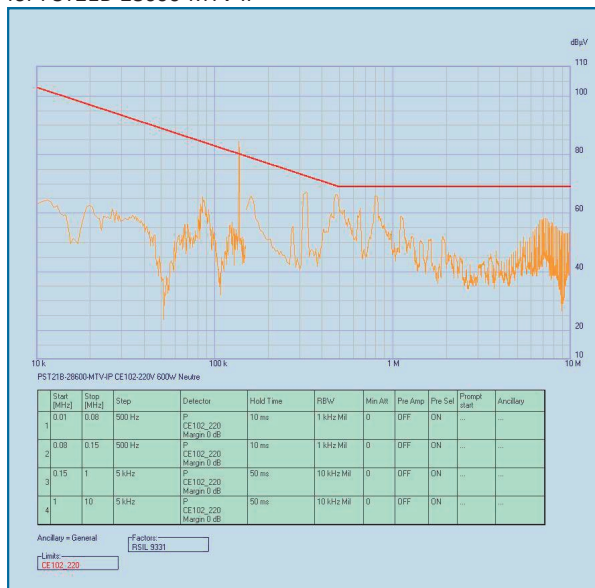

According to MIL-STD461E CE102 - 220V 600W Phase for PST21B-28600-MTV-IP

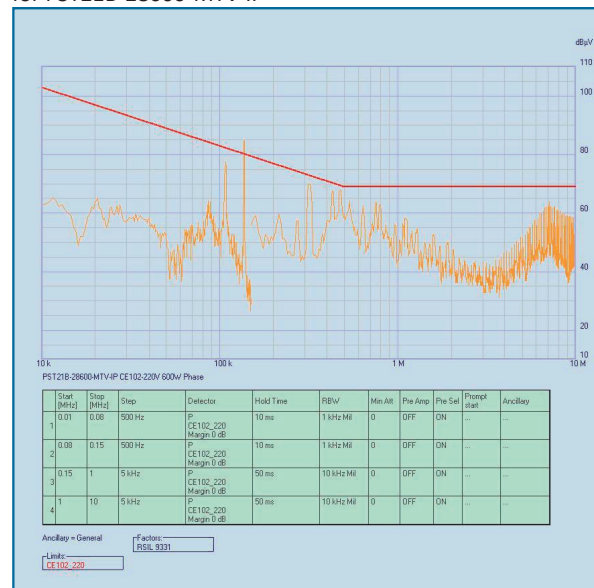



Immunity to Environmental Conditions

Test method	Standard	Test conditions	Status
Damp Heat	MIL STD 810F Proc. 507-2	Humidity 93 %, 40°C, 56 days	Option (-V), built to meet
Shock	MIL STD 810F Proc.516.3	20g / 18ms half size 5g / 30ms	Option (-M), built to meet
Vibrations	MIL STD 810F Proc. 514-5	4-80Hz (2,8m/s ²)/Hz, non operating 160-500Hz (0,175m/s ²)/Hz, non operating	Option (-M), built to meet

▼ Mechanical data

Size : 200 x 127 x 40 mm

Aluminum Natural

Weight :

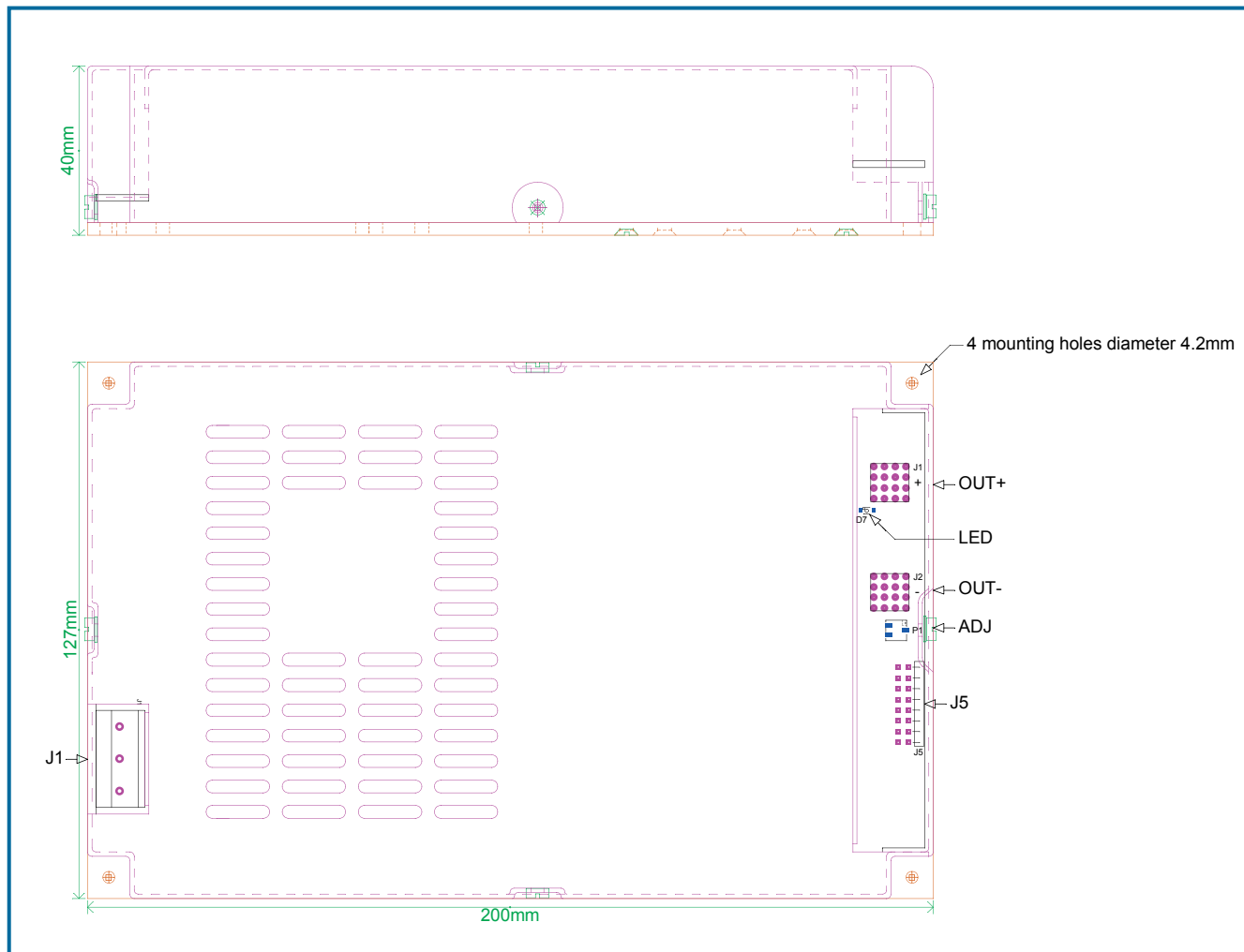

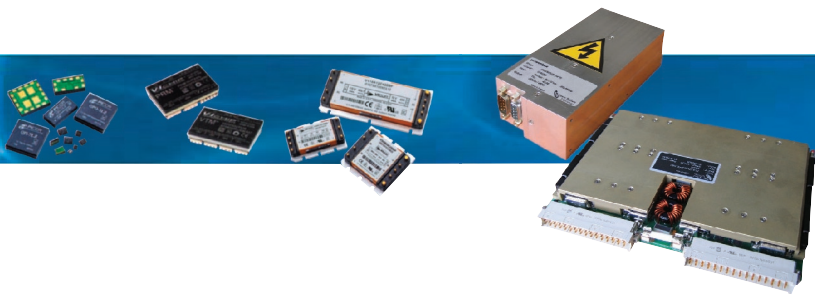

PST21B - H option

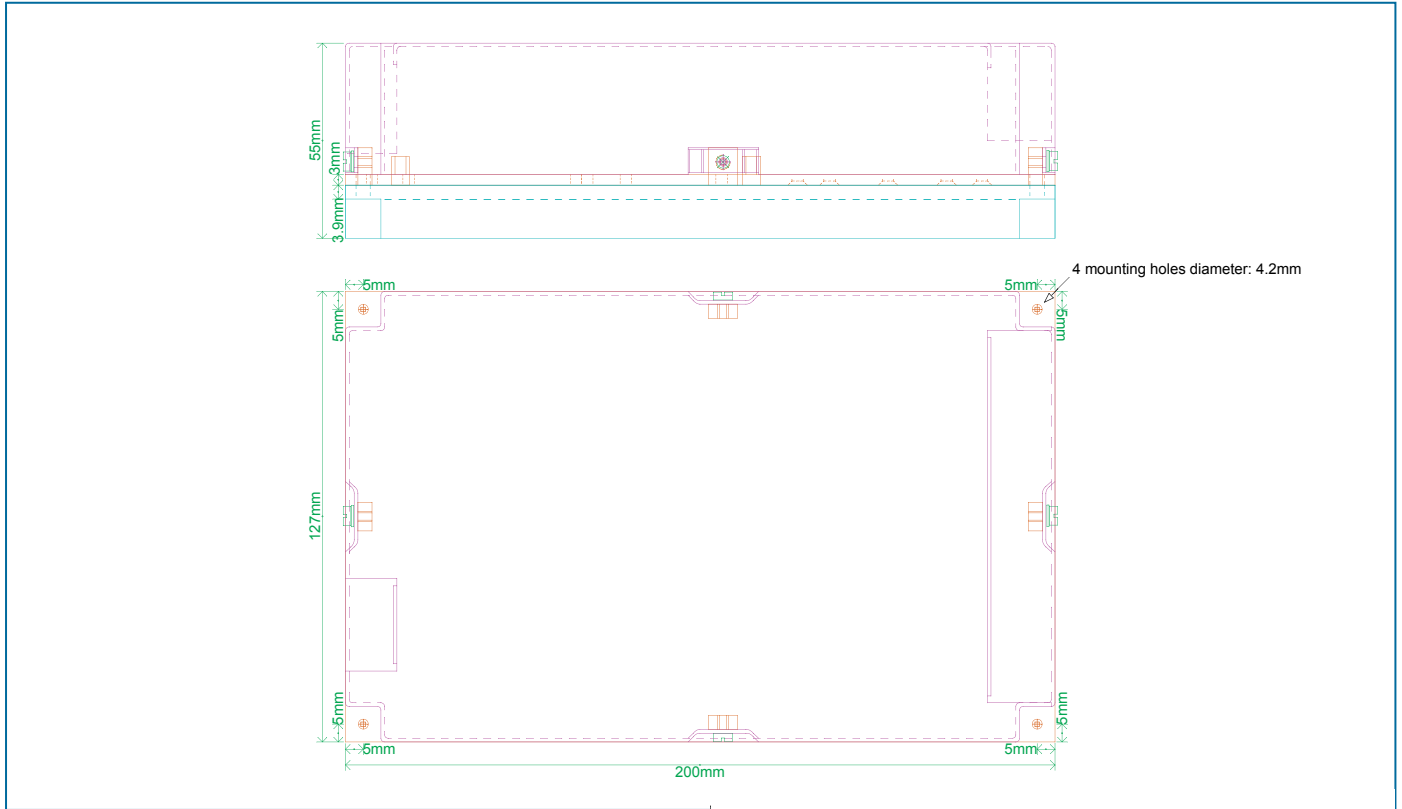

PST21B - H1 option

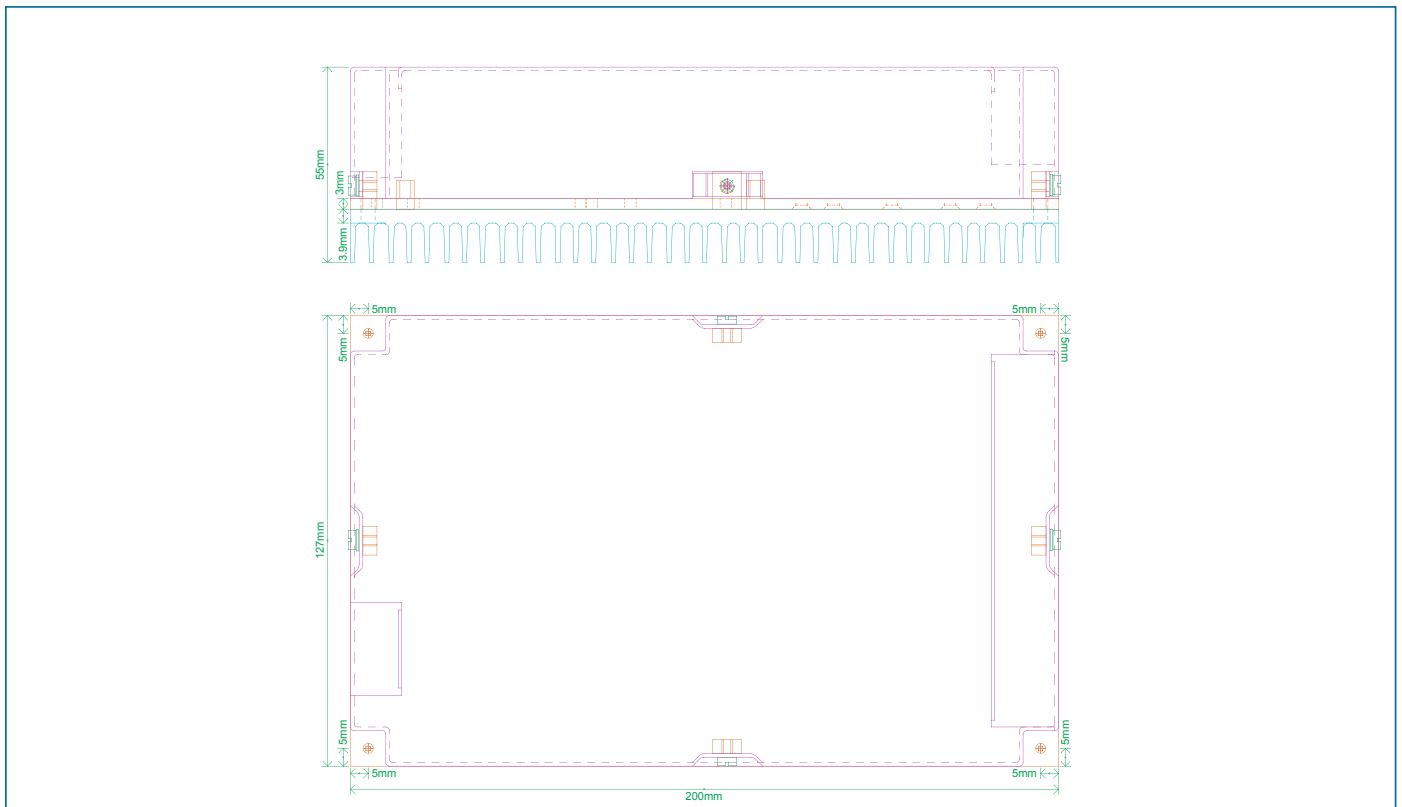



PST21B - IP option

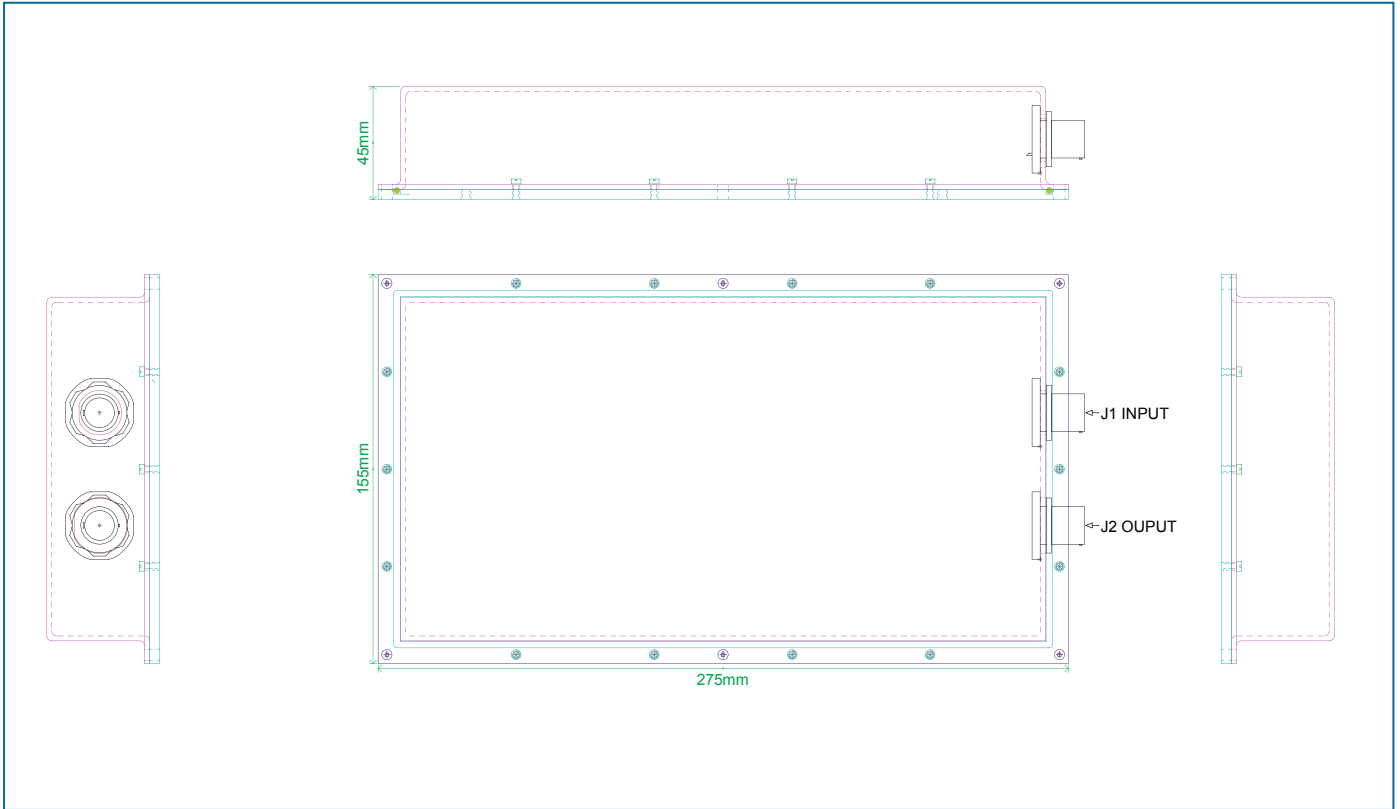



▼ Connector Pin Allocation

PST21B		
Description	PIN	Connector
Input Screw type connector GMKDS 3/3-7.62		
1	J1-1	Earth
2	J1-2	Neutral AC/N
3	J1-3	Line AC/L
Output Maxiboard Power connectors		
OUT+	J1	Würth Pres Fit M4 Ref : 7461095
OUT-	J2	Würth Pres Fit M4 Ref : 7461095
Output Miniboard Power connectors		
OUT1+	J1	Würth Pres Fit M3 Ref : 7461093
OUT1-	J2	Würth Pres Fit M3 Ref : 7461093
OUT2+	J3	Würth Pres Fit M3 Ref : 7461093
OUT2-	J4	Würth Pres Fit M3 Ref : 7461093
Output Microboard Power connectors		
OUT1+	J1	Würth Pres Fit M3 Ref : 7461093
OUT1-	J2	Würth Pres Fit M3 Ref : 7461093
OUT2+	J3	Würth Pres Fit M3 Ref : 7461093
OUT2-	J4	Würth Pres Fit M3 Ref : 7461093
OUT3+	J6	Würth Pres Fit M3 Ref : 7461093
OUT3-	J7	Würth Pres Fit M3 Ref : 7461093
Signals Würth 690368191472 Female 2*7 pins		
Microboard	Miniboard	Maxiboard
J5-1 : ACFAIL	J5-1 : ACFAIL	J5-1 : ACFAIL
J5-2 : PGOOD	J5-2 : PGOOD	J5-2 : PGOOD
J5-3 : RTN	J5-3 : RTN	J5-3 : RTN
J5-4 : INHIB	J5-4 : INHIB	J5-4 : NC
J5-5 : +5VAUX	J5-5 : +5VAUX	J5-5 : +5VAUX
J5-6 : S1+	J5-6 : S1+	J5-6 : NC
J5-7 : S1-	J5-7 : S1-	J5-7 : NC
J5-8 : ADJ1	J5-8 : ADJ1	J5-8 : NC
J5-9 : NC	J5-9 : PR1	J5-9 : PR1
J5-10 : NC	J5-10 : NC	J5-10 : NC
J5-11 : ADJ2	J5-11 : PR2	J5-11 : INHIB
J5-12 : S2+	J5-12 : S2+	J5-12 : S1+
J5-13 : S2-	J5-13 : S2-	J5-13 : S1-
J5-14 : ADJ3	J5-14 : ADJ2	J5-14 : ADJ1

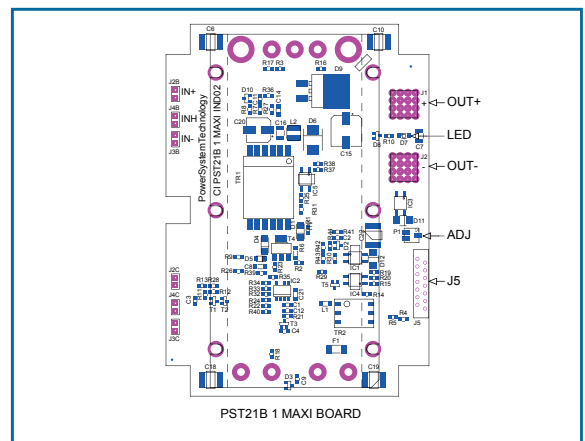
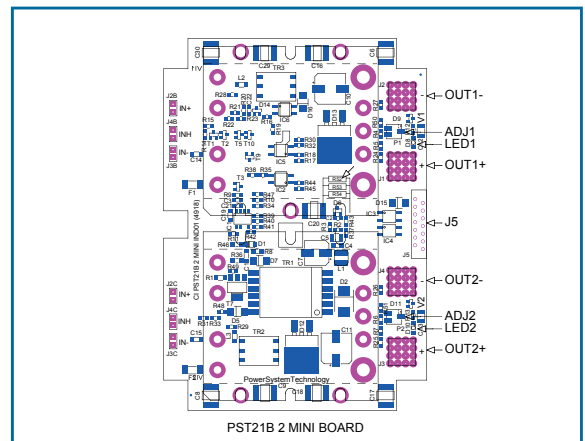
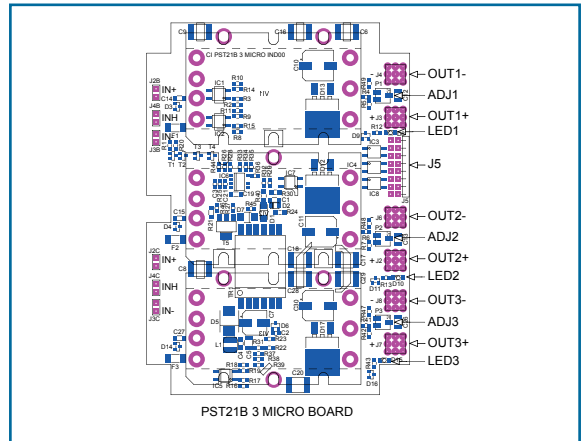



▼ Safety & Installation

These converters are components, intended exclusively for integration into other equipment by an industrial assembly process or by a professionally competent person. Installation must strictly follow the safety regulations in respect of the enclosure, mounting, creepage and clearance distances, markings of the end-use application. Connection to the system shall be made via the male connector Wurth.

The AC/L is internally fused. This fuse is designed to protect the converter against overcurrent caused by a failure, but may not be able to satisfy all requirements. External fuses in the wiring circuit to one or both input pins may be necessary to ensure compliance with local requirements.

Do not open the PSU, or the warranty will be invalidated. Make sure that there is sufficient thermal baseplate dissipation (max. temperature : 100°C). This should be verified by measuring the case of temperature at the specified measuring point, when the converter is operated in the end-use application.

Standards and Approvals

The converters are built to meet the safety standards IEC 60950-1, EN 60950-1.

'Built to meet' mentioned in the different paragraphs of the datasheet means that Power System Technology has designed the product to meet the standard but not certified it in a laboratory.

'Qualified' means that the test has been made in a certified laboratory.

Electric Strength

Characteristic		Input to Earth	Input to Output	Output to Earth	Output to Output	Unit
Electric strength	Design strength	1500	3000	500		Vrms
	Factory test for production units (>10s)	2000	2000	500		Vdc
Insulation resistance				> 100	>100	Mohms

Temperatures

Conditions		Standard			T option			Unit
		Min.	Typ.	Max.	Min.	Typ.	Max.	
Ambiant	Operating (see derating)	-20		+71	-40		+71	°C
Heatsink		-20		+100	-40		+100	
Storage	Not operating	-40		+125	-40		+125	

In operation, there is no power derating as long as the baseplate temperature is in the below indicated range.

Reliability

MIL-HDBK-217F, notice 2	Model	Heatsink Temp.	GB	GF
MTBF (Hours)	PST21B	40°C	285000	165000
		70°C	139500	82300
		100°C	86600	51000

MTBF calculation for a specific part number has to be ordered.

Cleaning Agents and Process

The converters are not hermetically sealed. In order to avoid possible damage, any penetration of liquids shall be avoided.

Isolation

The electric strength test is performed in the factory in accordance with IEC/EN 60950.



Options and configurations

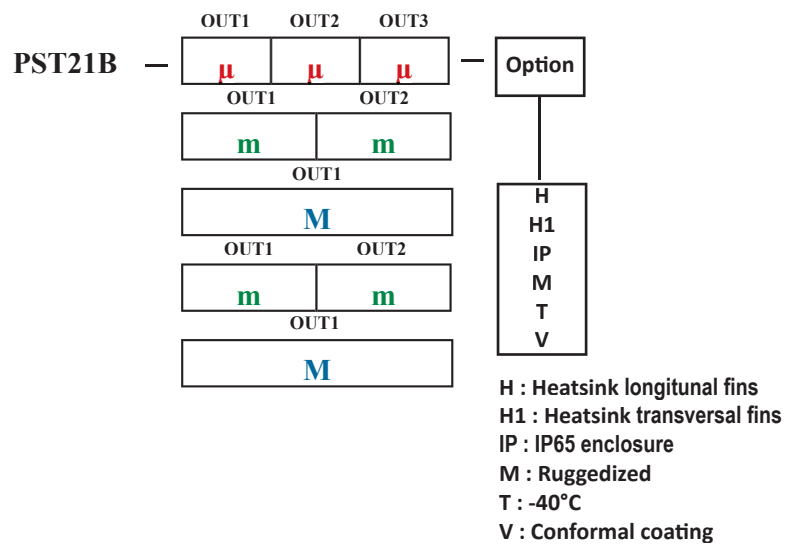
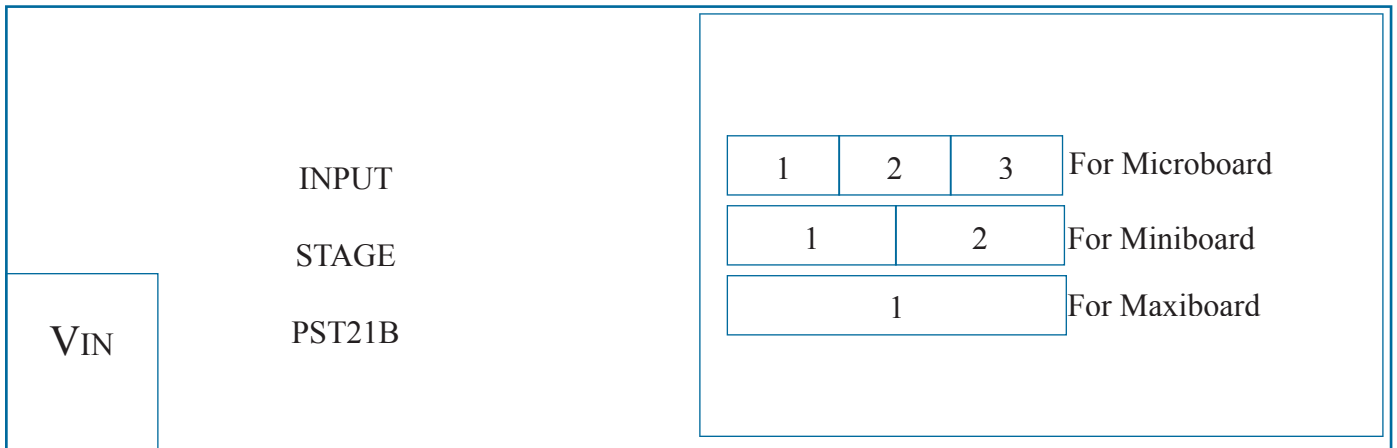



μ-μ-μ : Microboard out1, out2, out3 : Up to 3 outputs with micro-modules from 2V to 48Vdc 150W (see table page 1)

M : Maxiboard out1 : 1 output with maximodule from 2V to 54Vdc 600W (see table page 1)

μ		μ		μ	
V	W	V	W	V	W
N	N	N	N	N	N
2	50	2	50	2	50
3V3	50, 75	3V3	50, 75	3V3	50, 75
5	50, 100	5	50, 100	5	50, 100
8	100	8	100	8	100
12	75, 150	12	75, 150	12	75, 150
15	75, 150	15	75, 150	15	75, 150
24	75, 150	24	75, 150	24	75, 150
28	75, 150	28	75, 150	28	75, 150
36	75, 150	36	75, 150	36	75, 150
48	75, 150	48	75, 150	48	75, 150

M	
V	W
N	N
2	160
3V3	200, 264
5	300, 400
8	300, 400
12	400, 600
15	400, 600
24	400, 600
28	400, 600
32	600
36	400, 500, 600
48	400, 600
54	600

m-m : Miniboard out1, out2 : Up to 2 outputs with minimodules from 2V to 48Vdc 300W (see table page 1)

m		m	
V	W	V	W
N	N	N	N
2	100	2	100
3V3	100, 150	3V3	100, 150
5	150, 200	5	150, 200
8	200	8	200
12	200, 300	12	200, 300
15	200, 300	15	200, 300
24	200, 300	24	200, 300
28	200, 300	28	200, 300
36	200, 300	36	200, 300
48	200, 300	48	200, 300

EMPTY SLOTS ARE FILLED WITH "NN"

Example :

PST21B-48150-48150-48150-M (1 microboard with 3 outputs of 48V 150W with MIL-STD option)

PST21B-3V375-5100-12150 (1 microboard with 3 different outputs)