

PST22 450W

DC-DC

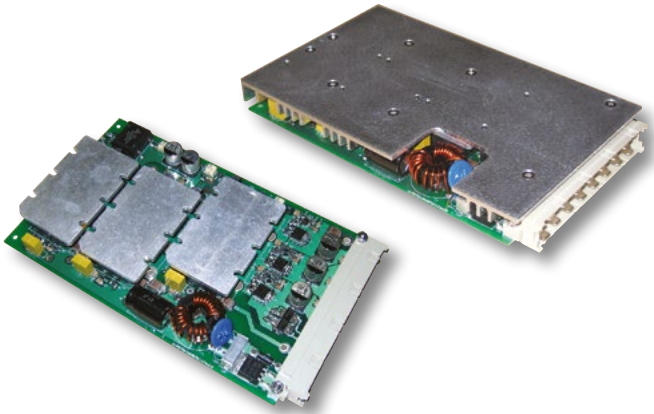

Features

- 24, 48, 72, 110Vdc input voltage ranges
- 1, 2 or 3 isolated outputs up to 450W
- Very high efficiency
- Surge and transient protection
- Many output configurations available
- Adjustable output voltage
- Redundant operation (N + 1) with active circuit (no diode losses)
- Extremely slim case (3U x 4TE (or 8TE) x 160mm)

Safety IEC/EN 62368-1, RoHS lead-free-solder compliant



Description

The PST22, very compact DC-DC converter in an eurocard format, incorporate input and output protection and filtering, signalling features, which are required in most of the severe environment for industrial, railways type of applications. The converter provides significant advantages such as flexibility of output configuration, high reliability thanks to the integration of Vicor Corp. modules, extremely high efficiency with secondary active MOSFET circuit for redundancy operation, very low ripple and noise levels, input-to-output isolation, soft start, overtemperature protection, input over/undervoltage lockout, parallel operation. The converters wide range of inputs are protected against surges and transients and EMI filtered. The outputs are continuously short-circuit proof. Series, Parallel and N+1 redundant operation are possible through an active MOSFET based circuit, improving significantly efficiency thus lowering power dissipation and allowing operation in high temperature environment, simplifying connection when several converters are connected in parallel without the need of wire connection between the converters to ensure good current sharing. LEDs at the front panel and an isolated Powergood signals indicate the status of the converter. V3 output can be either configured in high power version up to 150W with a DC-DC Vicor module or in a low power version up to 30W with switching regulator saving cost.

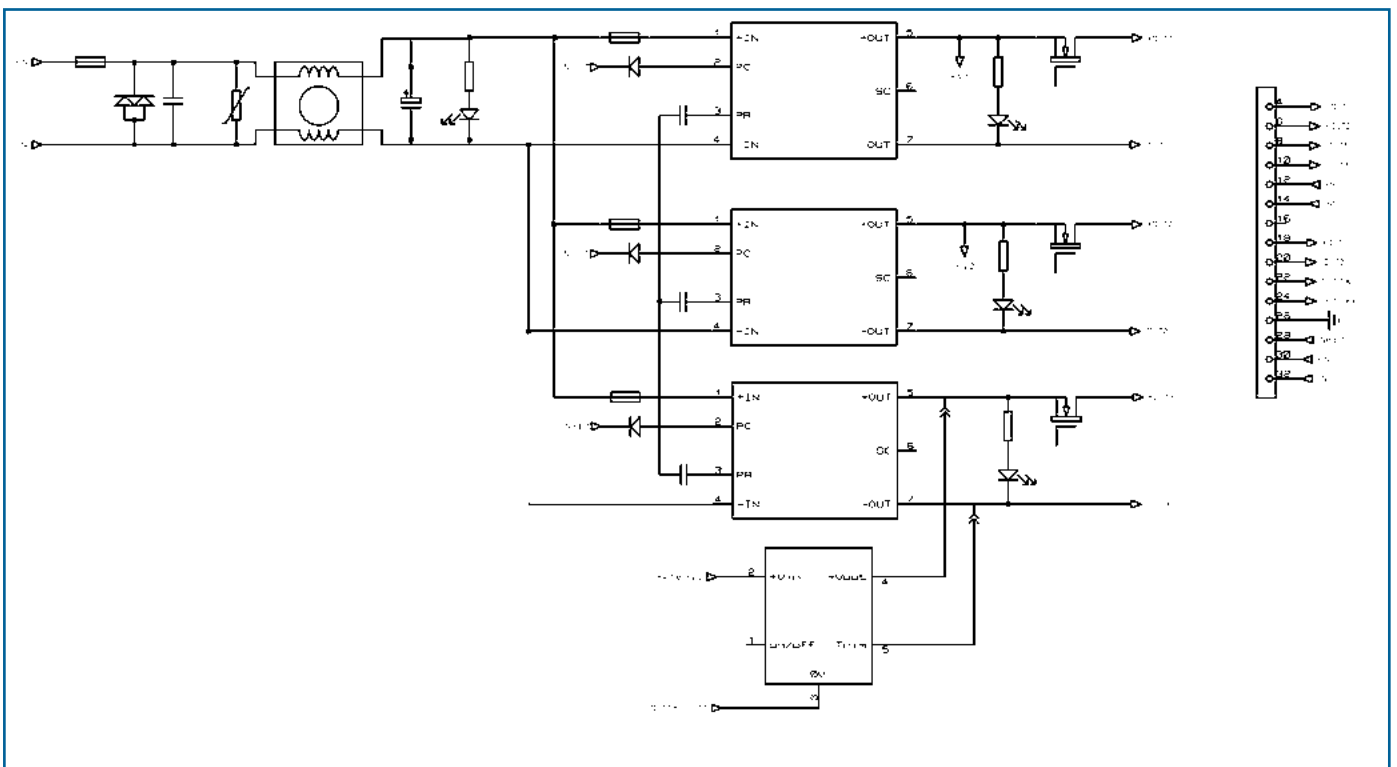

Options Description

No Front panel (F)

The PST22 is built as standard with a aluminum front panel as described in the mechanical data. In applications where the complete rack is covered by a single panel, the converter can be delivered without front panel.

-40°C operation (T)

The thermal grade of the Vicor the DC/DC converters used and other components are changed to comply with low ambient temperature.

N+1 Redundancy (R)

The PST22 is equipped with an internal active redundant MOSFET circuit providing very high reliability operation (described page 4) when R option.

Conformal coating (V)

During manufacturing process , when V option is specified, components and pcb are covered with an acrylic coating to address high level of ambient humidity application.

Very low profil 4TE (S)

With S option, the height will be reduced to 20,32mm for the front panel, making very suitable for low profil application. The heatsink being significantly reduced , thermal dissipation decrease and power

Input

Electrical Input Data

Input		24			48			72			110			Unit
Characteristics	Conditions	min	typ	max	min	typ	max	min	typ	max	min	typ	max	
Operating input voltage		18	24	36	36	48	75	43	72	110	66	110	154	V
Input surge	< 100ms			50			100			150			250	V
Undervoltage turn-on			17,5	17,9		35	35,8		41,7	42,6		64	65,4	V
Undervoltage turn-off		14,8	15,3		29,4	30,5		35,2	36,5		54	56		V
Overvoltage turn-off/on		36,3	37,8	39,6	76	79	82,5	111	115	121	154	162	170,9	V
Input current	Vin min		8	10		7	10		6	10		3	6	A
No-load input power			10			10			10			10		W
Peak inrush current	Vin max								180					A
Rise time inrush									20					µs
Start-up time									60					ms

Input Fuse

A fuse mounted inside the converter protects against damages in case of a failure. The fuse is not user-accessible. Reverse polarity at the input will cause the fuse to blow .

Model	Fuse type	Rating	Reference
24V	Littlefuse	15A	251015HE
48V	Bussman	15A	BK1/MCRW15A
72V	Busmann	15 A	BK1/MCRW15A
110V	Littlefuse	10A	251010HAT1L

Input Transient Protection / Electromagnetic Compatibility (EMC)

A VDR (Voltage Dependent Resistor) and a common mode input filter form an effective protection against input transients in severe environment like railways with EN50155.

Output

Electrical Output Data

General conditions :
25°C ambient.

Output data for V1, V2 . V3 configured in high Power Version (Vicor Module) - **Input 24, 110Vdc**

Output		3V3			5V			12V			15V			24V			28V			48V			Unit
Characteristics	Conditions	min	typ	max	min	typ	max	min	typ	max	min	typ	max	min	typ	max	min	typ	max	min	typ	max	
Output voltage		3V3			5			12			15			24			28			48			V
Trim range	Potentiometer	3		3,6	4,5		5,5	10,8		13,2	13,5		16,5	21,6		26,2	25,2		30,8	43,2		51,8	V
Overvoltage protection				4,5			6,5			14,9			18,5			29,1			34			58	V
Nominal output current		0	15	15	0	15	15	0	8	8,3	0	6	6,7	0	4	4,2	0	3,5	3,6	0	2	2,1	A
Output current limit			17,5	21		25	27		9,5	11		7,6	8,7		4,8	5,7		4,1	5		2,4	2,8	A
Output noise	20MHz		25			30			30			30			50			50			50		mVpp
Efficiency			75			83			87			88			87			87			86		%
Load Regulation	Vin nom.			0,4			0,4			0,4			0,4			0,4			0,4			0,4	%

Output data for V1, V2 . V3 configured in high Power Version (Vicor Module) - **Input 48, 72Vdc**

Output		3V3			5V			12V			15V			24V			28V			48V			Unit
Characteristics	Conditions	min	typ	max	min	typ	max	min	typ	max	min	typ	max	min	typ	max	min	typ	max	min	typ	max	
Output voltage		3V3			5			12			15			24			28			48			V
Trim range	Potentiometer	3		3,6	4,5		5,5	10,8		13,2	13,5		16,5	21,6		26,2	25,2		30,8	43,2		51,8	V
Overvoltage protection				4,5			6,5			14,9			18,5			29,1			34			58	V
Nominal output current		0	15	15	0	15	15	0	12	12,5	0	10	10	0	6	6,25	0	5	5,3	0	3	3,1	A
Output current limit			26	31		25	27		14,4	17,5		11,5	13,5		7,1	9		6,1	7,2		3,6	4,2	A
Output noise	20MHz		25			30			30			30			50			50			50		mVpp
Efficiency			75			83			85			84						83			84		%
Load Regulation	Vin nom.			0,4			0,4			0,4			0,4			0,4			0,4			0,4	%

Output data for V3 configured in low Power Version (switching regulator)

Output		3V3			5V			12V			15V			Unit
Characteristics	Conditions	min	typ	max	min	typ	max	min	typ	max	min	typ	max	
Output voltage			3,3			5		8	12			15		V
Trim range (factory set)		1		3,3	1		5	8		15	8		15	V
Overvoltage protection														
Nominal output current			6	6		5	8		3	3		3	3	A
Output current limit				12			16			4			4	A
Output noise				200			150			200			200	mVpp
Load regulation				0,4			0,4			0,4			0,4	%
Efficiency			86	90		83	90		89	91		89	91	%
Max capacitive Load				1000			1500			200			200	µF
		V2=3V3, 5V, 12V			V2=5, 12, 15, 24V			V2= 24V or 48Vdc						

Parallel and Series Connection

Any output can be connected in series with any other output from the same converter or from a separate converter, an external diode across each output may be required. The maximum output current of a serial-connected outputs is limited by the output with the lowest current limit. Output voltages above 48V (SELV - Safety Extra Low Voltage) require additional safety measures in order to comply with international safety requirements.

Parallel operation is very simple. When 2 outputs will be connected together, they will automatically current share without current share

Redundant Systems Operation

When systems require a very high level of reliability and should work normally in the event of a failure, N+1 redundancy is implemented where N is the number of converter to support power requirement. An example of a redundant system using 3 converters is shown Fig1. If one converter fail, the remaining ones still delivers the power to the loads. The 'paralleling' active circuit designed on every output of the PST22 replace the conventional diodes by MOSFET with very low RdsON thus divided by 10 the power losses.

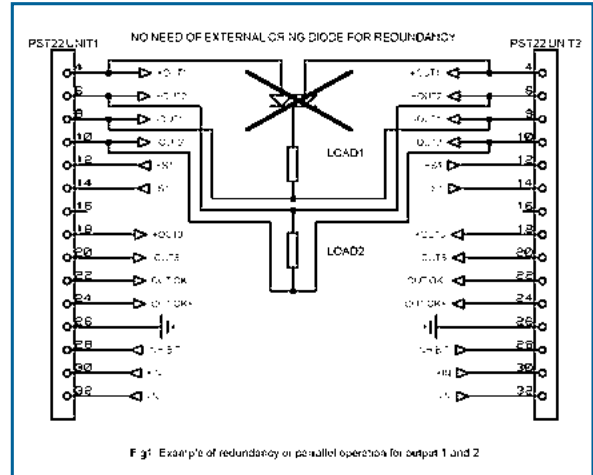

Fig1: Example of redundancy or parallel operation for output 1 and 2

Hold-up time

The converters provide low hold-up time. If a hold-up time is required (some railways applications for example), use external input capacitors of adequate size.

Formula for additional external input capacitor : $C = 2 * P_{out} * t_h * 100 / (V^2 - V_i^2) / n$

whereas :

- C = external input capacitance [mF]
- P_{out} = output power [W]
- n = efficiency [%]
- t_h = hold-up time [ms]
- V_i = minimum input voltage

Hot Swap

The low input inrush current allows the unit to be hot swapped. Nevertheless care must be taken with sense lines and we recommend to consult our technical support before operating in the mode.

Output Current Limitation

All outputs are continuously protected against short-circuit by a constant current limitation. (no foldback)

Thermal Considerations

When a converter is mounted in free air, in convection cooling, and is operating at its nominal output power at the max. ambient temperature, the temperature measured on the heatsink should not exceed 100°C. The derating curves show the max power available from the converter for the 4TE and 8TE versions versus ambient temperature.

Thermal protection

A temperature protection is integrated in each Vicor modules, disabling output when heatsink temperature exceed 105°C. the converter automatically restart, when the temperature drops below this limit.

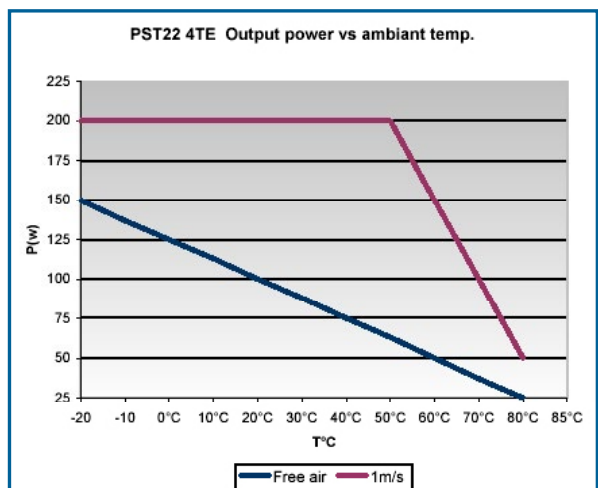
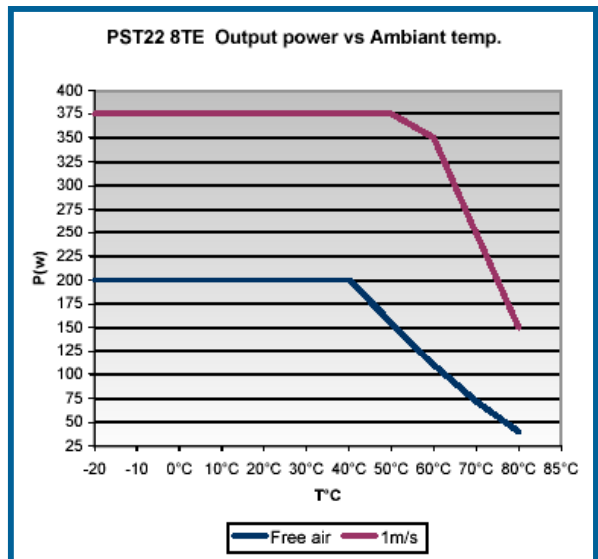

Auxiliary Functions

Primary Inhibit (Remote On/Off)

The inhibit input disables (logic low, pull down or short circuit between Inhibit and -In) or enables (logic high TTL, pull up or open-circuit between Inhibit and -In) the converter. This signal is referenced to the input voltage and will disable/enable all outputs at the same time. In systems consisting of several converters, this feature may be used to sequence the activation of the different converters.

Output Voltage Adjustment

The converter offer adjustment for each output voltage V1,V2,V3 though a potentiometer. In case of V3 is configured in low power version, the adjustment is factory set for V3.

Sense Lines

This feature enable compensation of voltage drop across the connector contacts and the load lines. This functionality is implemented on V1 only.

The voltage between any sense line and its respective power output pin (as measured on the connector) should not exceed the following values

Output type	Total drop	Negative line drop
V1	< 0.5V	< 0.25V

Powergood

The converter has different levels of signalling the good operation:

An input green led on the front panel indicate that input voltage is present at the input after the internal fuse .

Three green leds on the front panel indicate the presence of each output voltage .

An open collector Powergood (pin 22 and 24) is active low if all the output voltages are working correctly.

Waveforms

Typical values for PST 2272-5V100-24150-

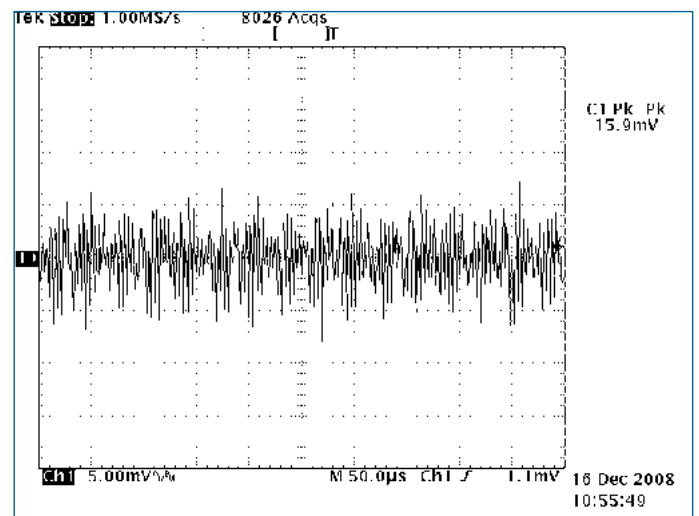
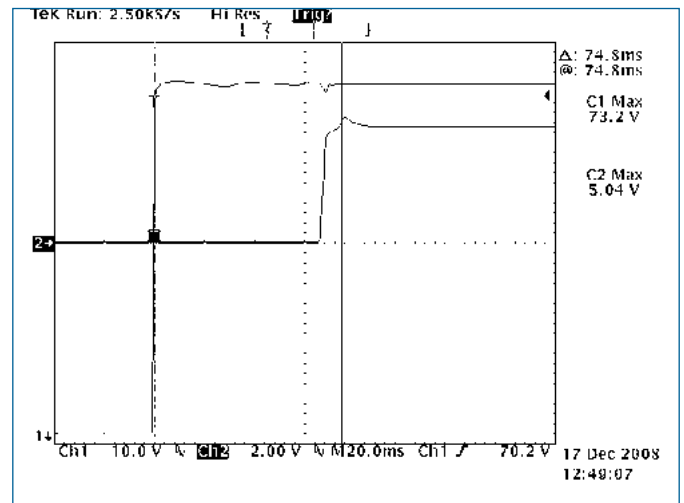
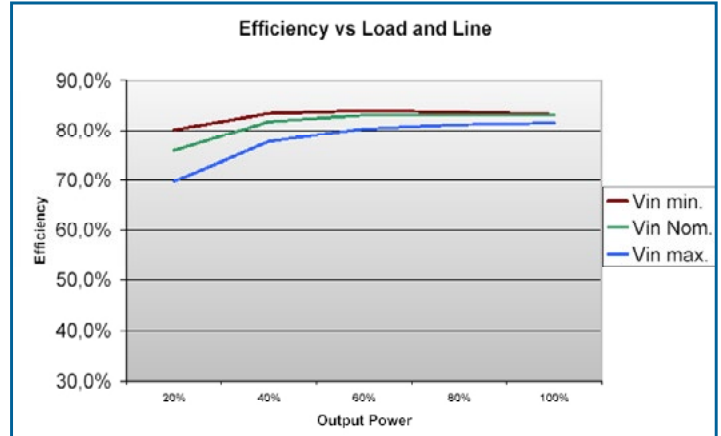

Electromagnetic

Electromagnetic Immunity

	Standard	Level	Value	Waveform	Source imped.	Test procedure	Mode
Supply surge	EN50155	B	1.4 * VIN	0,1 / 1 / 0,1 s	1 Ohm	1 positive surge	OP
Direct transients	EN50155	D	1800V	5 / 50 µs	5 Ohms	5 pos., 5 neg.	OP
Surges	EN 61000-4-5	3	2000V	1,2 / 50 µs	12 ohms		OP
Electrostatic discharge (to case)	EN 6100-4-2	4	8000V	1 / 50µs	330 Ohms	10 pos., 10neg.	OP
Electrical fast transients/burst	EN 61000-4-4	4	4000V	5 / 50µs	50 ohms		OP

Electromagnetic Emissions

Level according to EN55011, EN55022, EN50155, EN50121-3-2

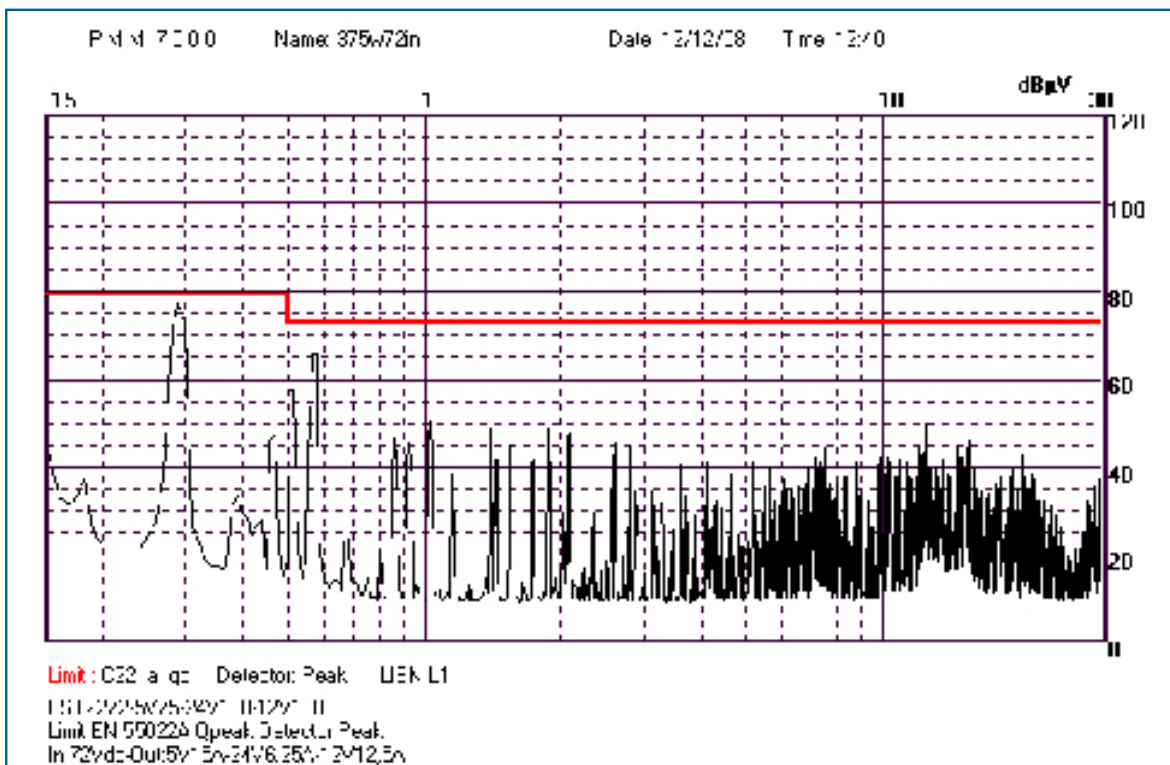

Immunity to Environmental Conditions

Test method	Standard	Test conditions	Status
Damp Heat	MIL STD 810D Proc. 507-2	Humidity 93 %, 40°C, 56 days	Conformal coating option only, built to meet
Shock	MIL STD 810D Proc.516.3 EN 50155	50g / 11ms 5g / 30ms	Built to meet
Vibrations	MIL STD 810D Proc. 514-3		Built to meet

Mechanical data

Solder side of the PCB protected by PBT sheet.

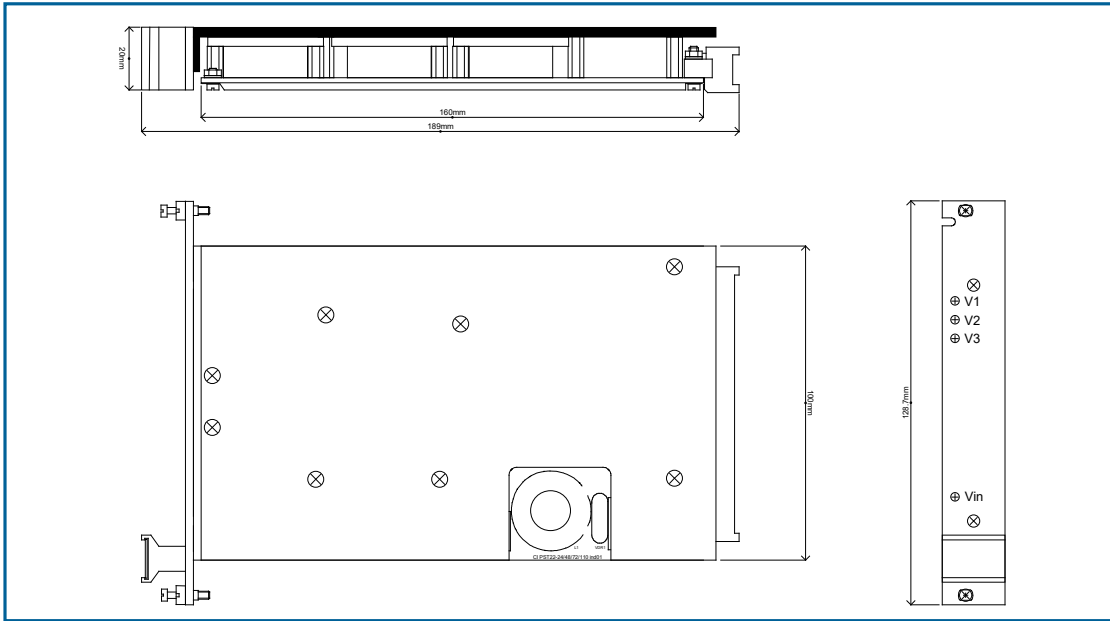

S option : 4TE version

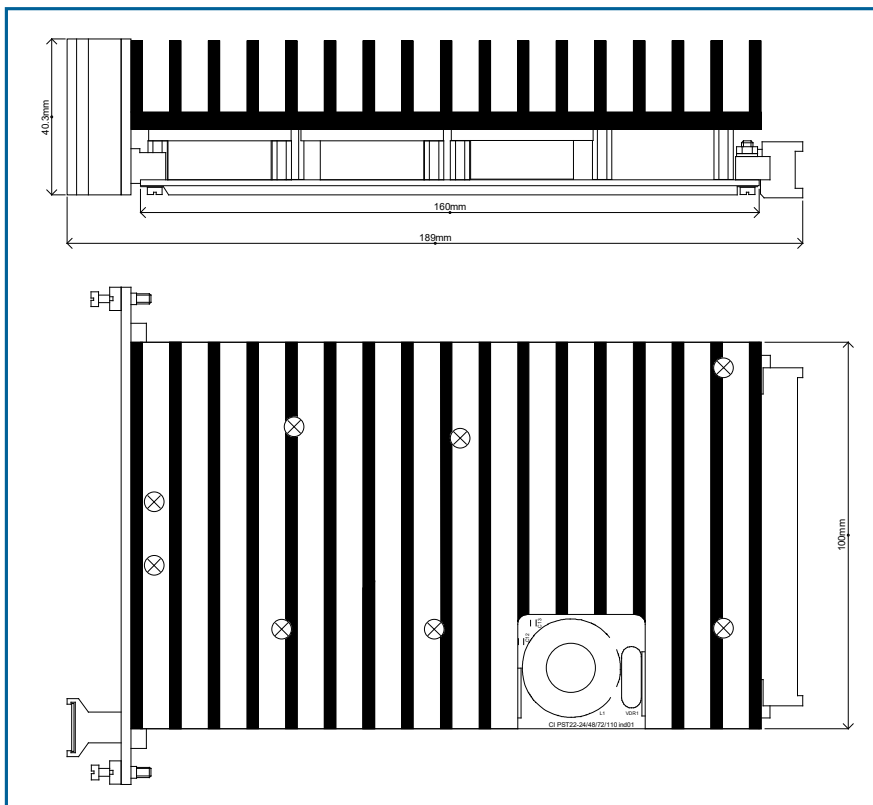

8TE version

▼ Safety and Installations Instructions

Connector Pin Allocation



Ref : 05H15MGWVZ32/K1 - 2E ROLF HILLER

DIN 41612 Male H15 - Short version

PIN	Description	
4	Vo1+	Output 1+
6	Vo2+	Output 2+
8	Vo1-	Output 1-
10	Vo2-	Output 2-
12	S1+	Output 1 Sense +
14	S1-	Output 1 Sense -
16	NC	No connection
18	Vo3+	Output 3+
20	Vo3-	Output 3-
22	Out OK-	Output good collector
24	Out OK+	Output good emitter
26	Ground	Ground
28	Inhibit	Inhibit
30	VI+	Input +
32	VI-	Input -

Installations Instructions

These converters are components, intended exclusively for integration into other equipment by an industrial assembly process or by a professionally competent person. Installation must strictly follow the safety regulations in respect of the enclosure, mounting, creepage and clearance distances, markings of the end-use application.

Connection to the system shall be made via the female connector H15. Pin 26 (Earth) is a leading pin and is connected to the case. For safety reasons it is essential to connect this pin to the protective earth of the supply system.

The +Vin is internally fused. This fuse is designed to protect the converter against overcurrent caused by a failure, but may not be able to satisfy all requirements. External fuses in the wiring circuit to one or both input pins (30 or 32) may be necessary to ensure compliance with local requirements.

Do not open the converters, or the warranty will be invalidated. Make sure that there is sufficient airflow available for convection cooling. This should be verified by measuring the case of temperature at the speci-

Standards and Approvals

The converters are built to meet the safety standards IEC 62368-1, EN 62368-1, UL 62368-1 and CSA 62368-1.

Electric Strength

Characteristic		Input to Earth	Input to Output	Output to Earth	Output to Output	Unit
Electric strength	Design strength	1500	3000	500		Vrms
	Factory test for production units (>10s)	2000	2000	500		Vdc
Insulation resistance				> 100	>100	Mohms

Temperatures

Conditions		Standard			T option			Unit
		Min.	Typ.	Max.	Min.	Typ.	Max.	
Ambient	Operating (see derating)	-20		+71	-40		+71	°C
Heatsink		-20		+100	-48		+100	
Storage	Not operating	-40		+125	-40		+125	

Reliability

MIL-HDBK-217F, notice 2	Model	Heatsink Temp.	GB	GF
MTBF (Hours)	PST2272 3 outputs	40°C	335000	195000
		70°C	165000	97500
		100°C	103500	61500

Cleaning Agents and Process

The converters are not hermetically sealed. In order to avoid possible damage, any penetration of liquids shall be avoided.

Railway Application

The converters have been designed observing the railway standards EN 50155 and EN 50121. All boards can be protected by a conformal coating as an option (-V).

Isolation

The electric strength test is performed in the factory in accordance with IEC/EN 62368.

Options and configurations

Pout max : 200W
IN max : see table page 2

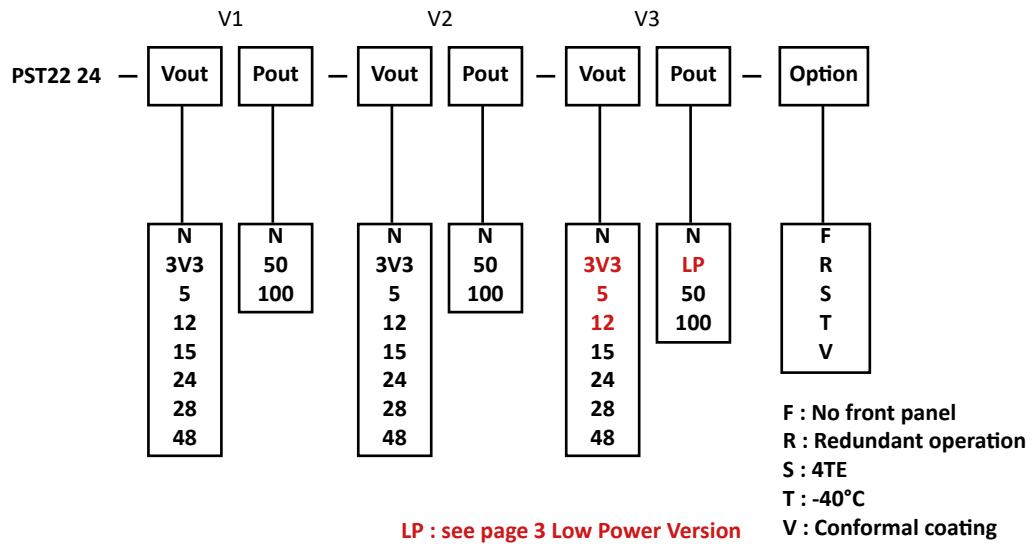

Pout max : 400W
IN max : see table page 2

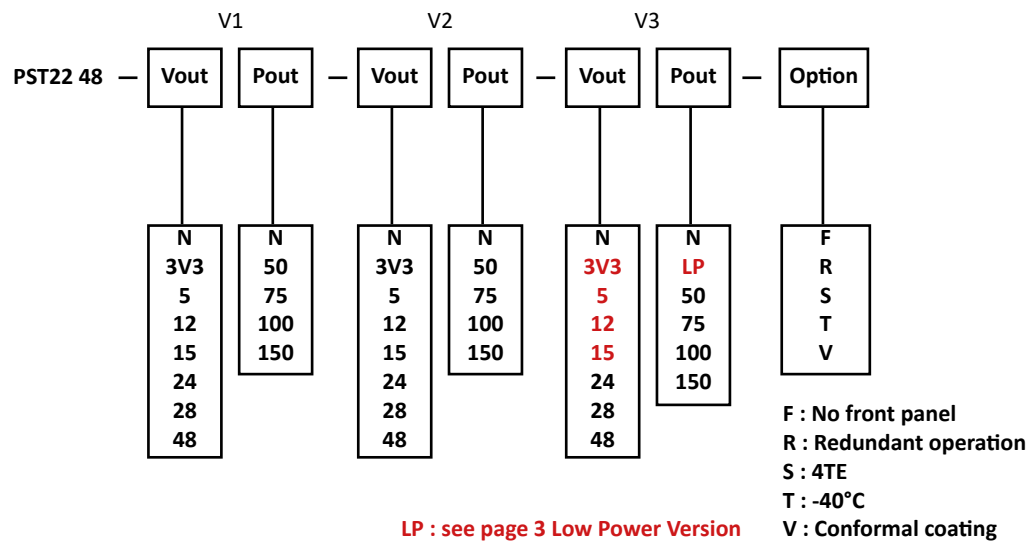

Options and configurations

Pout max : 450W
IN max : see table page 2

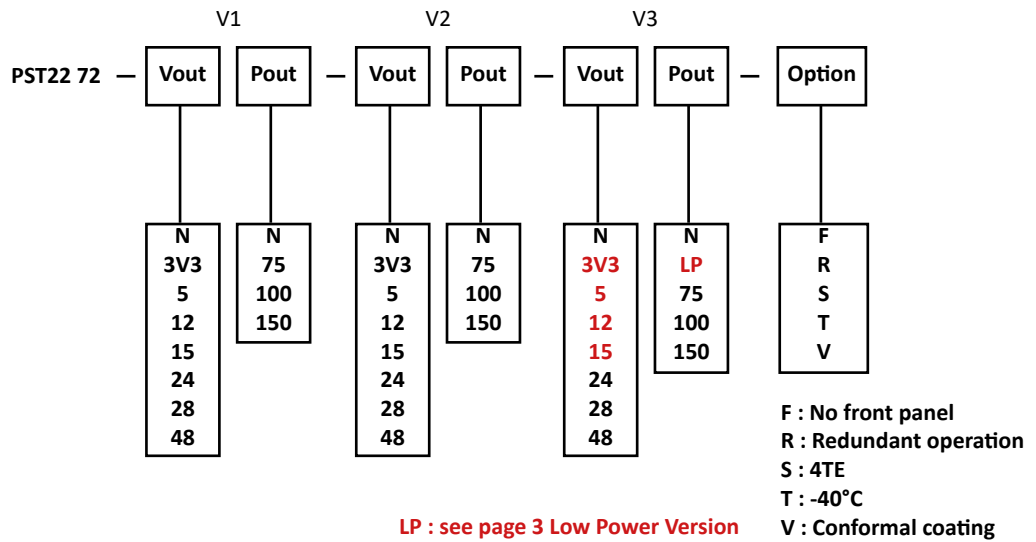

Pout max : 300W
IN max : see table page 2

