

# PST14X 320W

## DC-DC Conduction cooled



### Features

- Input ranges: 9-50Vdc, 18-36Vdc, 16-50Vdc
- 1 output 3V3 to 48Vdc, 320W max.
- 50\*160\*25mm
- Automatic reverse polarity, Surge and transient protected
- 40°C to 100°C baseplate
- MV Option: MILSTD1275 and Severe environment
- Parallel operation up to few kWatts

Safety IEC/EN 62368-1, RoHS lead-free-solder compliant



### Description

PST14X, very high power density 320W DC-DC converter in conduction cooled format, incorporates input EMI filtering, input transient protection, output protections, very robust mechanical package and connection required in most of the severe environment for industrial, railways, defense type of applications. The converter provides high power density thanks to the integration of Vicor Corp. DCM modules, high efficiency, input-to-output isolation, soft start, overtemperature protection, input over/undervoltage lockout. The outputs are short-circuit proof. The 100°C baseplate operation allows operation in high temperature environment. The output can be configured in many different output voltages from 3,3V to 48Vdc, others possibilities are even possible as semi-standard versions. With the -MV option, the converter is protected against surges and transients MIL-STD-704 and MIL-STD-1275, EMI filtered built to meet MIL-STD 461 and ruggedized according MIL-STD-810.

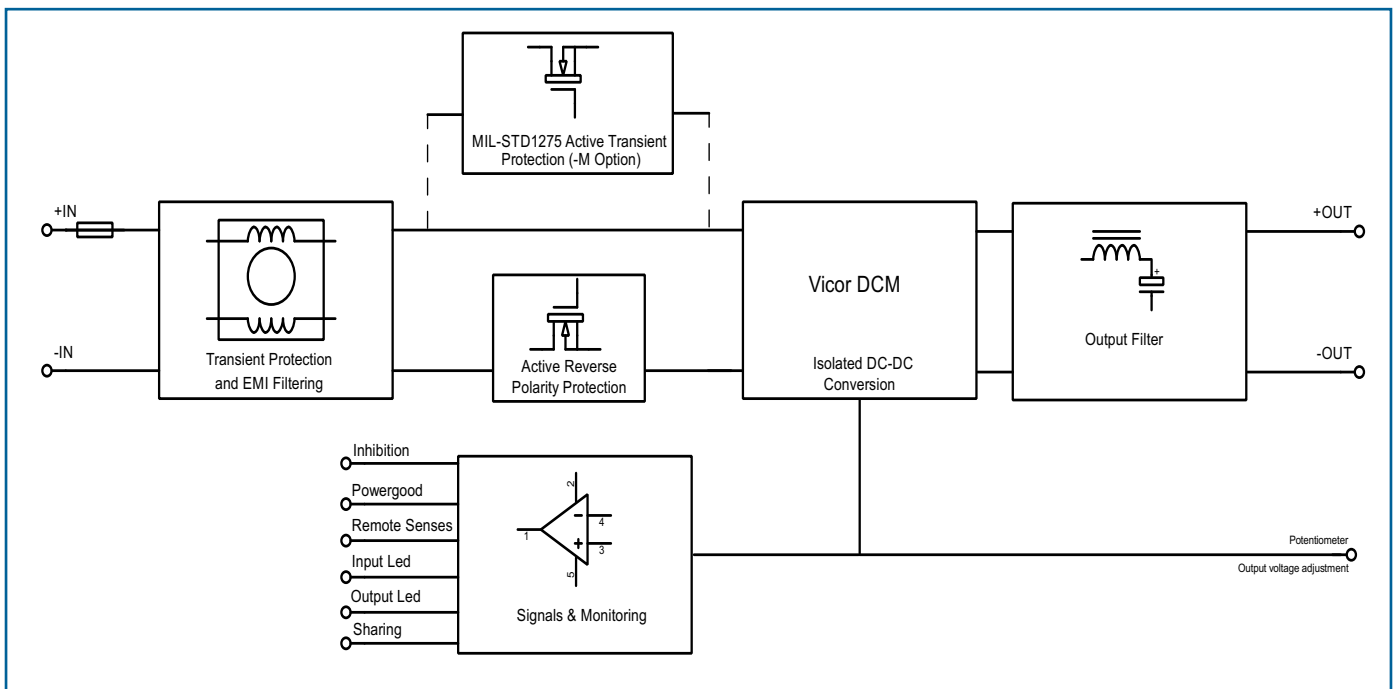

## Input

### Electrical Input Data

Input Characteristics	Conditions	12V			24V			28V			Units
		min	typ.	max	min	typ.	max	min	typ.	max	
Operating input voltage		9		50	18		36	16		50	V
Absolute Max. Rating				65			65			65	
Undervoltage lockout		5,4		8,6	10,8		17,1	9,6		12	V
Undervoltage Recovery				9			18			16	V
Overvoltage lockout	If no -M option			55			45			58	V
Overvoltage Recovery	If no -M option	50			36			50			V
Input current	Vin min			20			20			20	A
Input power	No load			11			11			12	W
	Disabled			1			1			1	W
Start-up time				10			10			10	ms

### Input Transient Protection

A Transil diode and a common mode input filter form an effective protection against input fast transients in severe environments like railways.

When -MV option is defined for PST14X, the unit incorporates an active protection circuit against high energy transient MIL STD 1275, DO160.

### Input Fuse

A fuse mounted inside the converter protects against damages in case of a failure. The fuse is not user-accessible.

### Input Reverse Polarity

An active Mosfet circuit placed internally at the input will block the current in case of reversed polarity, no damage to the unit and unit will come back to normal operation when resumed.

### Input Inrush Current

They are no inrush limitation other than input serial choke from EMI filter and these included into the Vicor DCM converter as the input capacitors are quite limited. See above table for the values.

### Input UVP/ OVP

The PST14X includes input undervoltage protection (UVP) and overvoltage protection (OVP) which will stop the converter in the event of an under/overvoltage and restart when input comes back in its normal range. See table above for the value according input range. Do not exceed absolute maximum rating in any case. When the -MV option is selected, an overvoltage with a duration less than 100ms will be clamped by the active input protection, if any longer units will stop and restart after several seconds.

### Waveforms

#### Inrush Current : PST14X28-28320

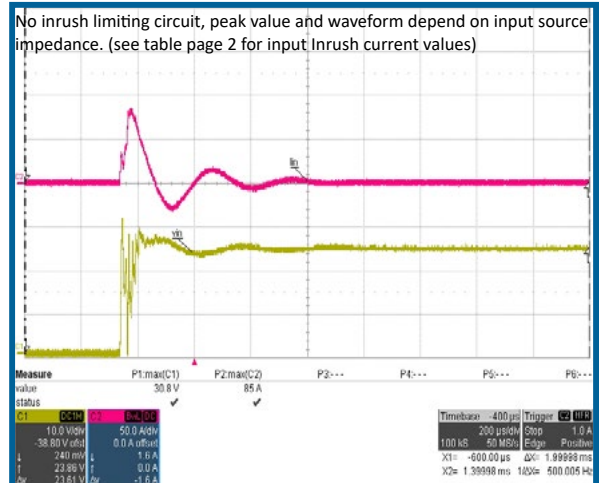

#### 100V 50ms Transient protection (-M option) : PST14X28-28320-MV



#### Start-up time : PST14X28-28320

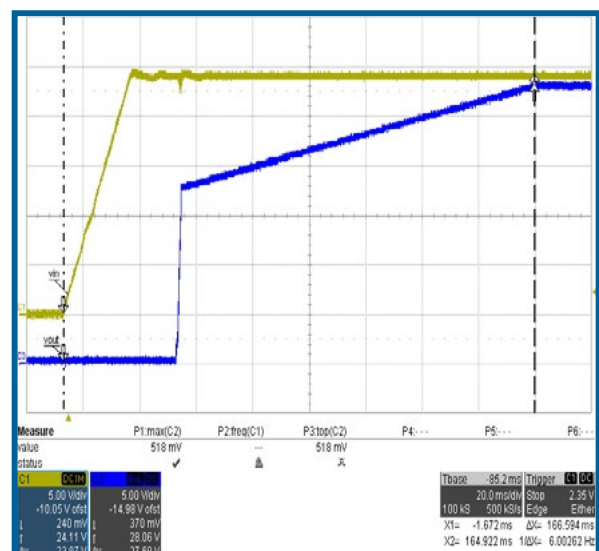

## Output

### Electrical Output Data

General conditions : 25°C ambient.

1) Latched shutdown - 2) Output voltage falls < 95 % of nominal - 3) Nominal input, full load, 20MHz bandwidth - 4) Nominal input, full load - 5) No load to full load, nominal input

Part Number	Output Voltage		Output Power			Voltage Adjustment			Overvoltage Protection (1)			Output Current			Output Current Limit (2)			Output Noise (3)			Efficiency (4)			Load regulation (5)
	V	W	V		V		A		%		mVpp		%		V									
	Nom.	Nom.	Min.	Typ.	Max.	Min.	Typ.	Max.	Min.	Typ.	Max.	Min.	Typ.	Max.	Min.	Typ.	Max.	Typ.						
12Vin																								
PST14X12-3V380	3V3	80	3.00	3.63	4.1	0	24.3	100	120	136	70		85	0.1										
PST14X12-580	5V	80	4	5.5	6.32	0	16	100	120	145	80		85.5	0.1										
PST14X12-12160	12V	160	9.6	13.2	15	0	13.4	100	120	150	115		89	0.1										
PST14X12-15160	15V	160	12	16.5	19	0	10.7	100	120	139	115		89	0.1										
PST14X12-24160	24V	160	19.2	26.4	30.3	0	6.7	100	120	145	170		88	0.1										
PST14X12-28160	28V	160	22.4	30.8	35.4	0	5.8	100	120	140	105		89	0.1										
PST14X12-48160	48V	160	38.4	52.8	60.7	0	3.4	100	120	140	200		88	0.1										
24Vin																								
PST14X24-5180	5V	180	4	5.5	6.92	0	36	100	120	139	80		89	0.1										
PST14X24-12320	12V	320	9.6	13.2	15	0	26.6	100	120	130	115		90	0.1										
PST14X24-15320	15V	320	12	16.5	18.7	0	21.4	100	120	130	115		90.5	0.1										
PST14X24-24320	24V	320	19.2	26.4	30	0	13.4	100	120	134	170		90	0.1										
PST14X24-28320	28V	320	22.4	30.8	35	0	11.4	100	120	142	105		91	0.1										
PST14X24-36320	36V	320	28.8	39.6	45	0	8.9	100	120	137	105		91	0.1										
PST14X24-48320	48V	320	38.4	52.8	60	0	6.6	100	120	143	220		90.5	0.1										
28Vin																								
PST14X28-3V3120	3V3	120	3	3.6	4.17	0	36.4	100	120	145	90		87	0.1										
PST14X28-5180	5V	180	4	5.5	6.92	0	36	100	120	131	90		88.5	0.1										
PST14X28-12320	12V	320	9.6	13.2	15.6	0	26.6	100	115	132	115		89.5	0.1										
PST14X28-15320	15V	320	12	16.5	18.7	0	21.4	100	120	130	115		90	0.1										
PST14X28-24320	24V	320	19.2	26.4	30	0	13.4	100	120	130	170		89	0.1										
PST14X28-28320	28V	320	22.4	30.8	35	0	11.4	100	115	123	105		90.5	0.1										
PST14X28-48320	48V	320	38.4	52.8	60	0	6.6	100	120	143	220		90	0.1										

### Output Current Limitation

See Electrical output data for current limitation value according part-number.

The converter output is continuously protected against short-circuit or current limitation by disabling the power train when output current goes above the value from the table page 3. When the default disappears, the converter will go back to normal operation after initialization.

### Output OVP

The PST14X includes output overvoltage protection (OVP) which will stop the converter in the event of an overvoltage and restart when input comes back in its normal range. See table above for the value according output voltages. Nevertheless exceeding these value may damage the converter.

### Parallel Connection

**Before revision 5(IND05):** Parallel operation is possible up to 8 PST14X to increase output power. The paralleling and current sharing between the units will work in droop share mode using the output circuit CIE14X-POB and cable CAB CIE14X POB. Output voltage of each unit should be as close as possible (+50mV at 50% load) to ensure proper current sharing between the paralleled units.

**From revision 5(IND05):** Parallel operation is possible to increase output power. In standard, the unit is delivered in standalone configuration for single converter use: switch accessible through the cover and switched to «standalone» position according to label indication. To parallelize multiple converters, set the switch in position «Array». The output voltage of each unit must be set up separately at the same value, thanks to the potentiometre (P2) accessible through the cover, with no load at the output, before parallelizing to ensure proper current sharing between the units. Switch from revision 5(IND05):



### Redundant Systems Operation

When systems require a very high level of reliability and should work normally in the event of a failure, N+1 redundancy is implemented where N is the number of converter to support power requirement. If one converter fail, the remaining ones still delivers the power to the loads.

Use of CIE 14X-POB and CAB CIE14X-POB accessories ensures proper parallel operation and N+1 redundancy through active circuit.

### Hold-up time

The converter provides limited hold-up time. If a hold-up time is required (some railways applications for example), use external input capacitors of adequate size.

Formula for additional external input capacitor :  $C = 2 * P_{out} * t_h * 100 / (V_i^2 - V^2) / n$

whereas :

- C = external input capacitance [mF]
- P<sub>out</sub> = output power [W]
- n = efficiency [%]
- t<sub>h</sub> = hold-up time [ms]
- V<sub>i</sub> = minimum input voltage
- V = Input voltage level before interruption

### Thermal Considerations

The converter is designed to be mounted on a dissipative area, in conduction cooling mode. The max. operating temperature is the temperature of the baseplate which should not exceed 100°C.

Addition of grease or thermal pad between the converter baseplate and the chassis is mandatory. When used with heatsink in conduction cooled or air forced, the thermal impedance R<sub>th</sub> (°C/W) of the heatsink should be calculated taking into account max baseplate temp. 100°C (T<sub>b</sub> max.), max operating ambient (T<sub>a</sub> max.), dissipated power (P<sub>diss</sub>).

$$R_{th} = (T_b \text{ max.} - T_a \text{ max.}) / P_{diss}$$

As an example, see R<sub>th</sub> of H and H1 heatsink option in the option description paragraph and graph of power derating .

### Thermal protection

A temperature protection is integrated in each Vicor module, disabling output when heatsink temperature exceeds 105°C. The converter automatically restarts, when the temperature drops below this limit. Nevertheless, exceeding the max operating temperature may cause failures of the converter.

### Waveforms

#### Current Limitation PST14X28-28320

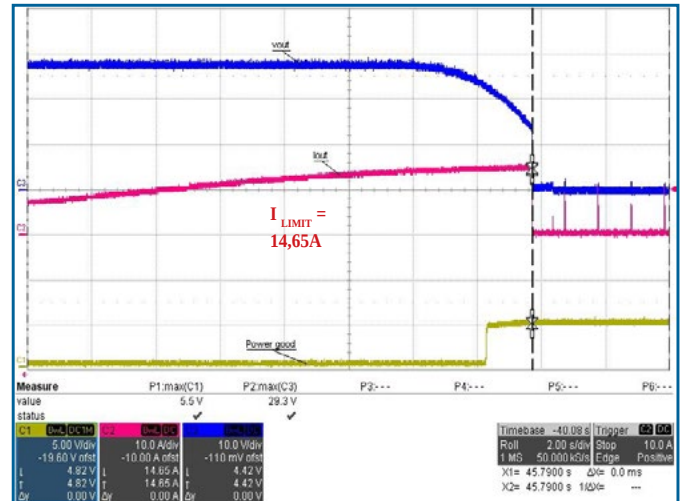

#### Short Circuit limitation PST14X28-28320

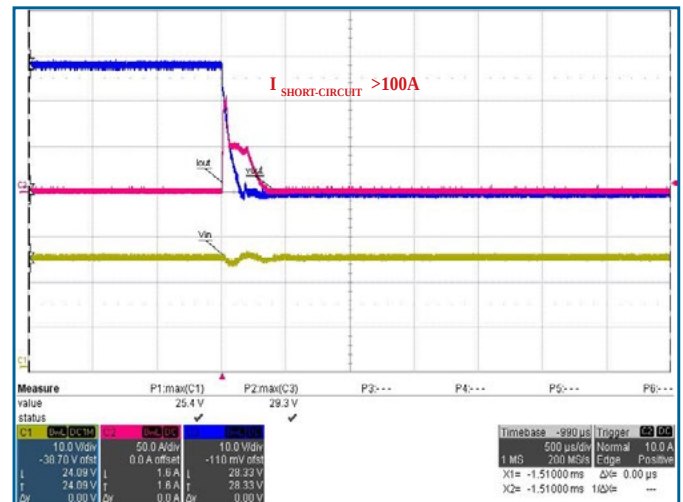

#### Power vs Ambient temperature (vertical position) PST14X28-28320

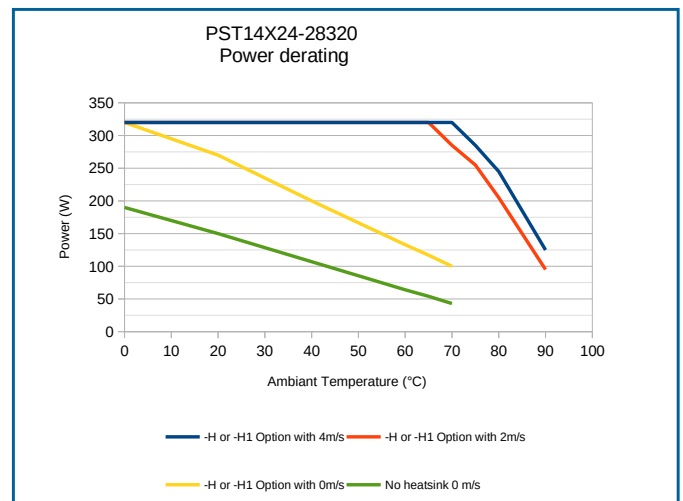



## Environmental

### Functionalities and compliance table

Functionalities	Conditions	Input 12V		Input 24V	Input 28V	
		PST14X12-xxx	PST14X12-xxx-MV	PST14X24-xxx	PST14X28-xxx	PST14X28-xxx-MV
Parallel operation	Droop current share with CIE POB accessories	√	√	√	√	√
Redundant operation	Droop current share with CIE POB accessories	√	√	√	√	√
Remote senses		√	√	√	√	√
MIL COTS version	-MV option for 12 & 28 Vin		√			√
Conformal coating	-V option	√	√	√	√	√
-40°C Operation	standard	√	√	√	√	√
MIL-STD-704 A,C,D,E,F, 28V Steady State	built to meet, -MV option		√			√
MIL-STD-704 A,C,D,E,F 28V Surges High Transients	built to meet, -MV option		√			√
MIL-STD-704 A,C,D,E,F 28V Surges Low Transients	built to meet, -MV option		√			√
MIL-STD-704 C,D,E,F 28V Surges Low Transients	built to meet, -MV option		√			√
MIL-STD-704 A,C,D,E,F 28V Spikes	built to meet, -MV option		√			√
MIL-STD-810E (Shocks, Vibrations, Accelerations, Humidity)	built to meet, -MV option		√			√
MIL-STD-461 Conducted Emission CE101, CE102	See Curves below, built to meet, -MV option		√			√
MIL-STD-461 Conducted Susceptibility CS101,114,115,116	built to meet, -MV option		√			√
MIL-STD-1275 A,B,D Steady State, Surges and Spikes	100V/50ms, 250V/70uS		√			√
MIL-STD-1275 A,B,D Surges	15V operation		√			
MIL-STD-1275 A,B,D Starting disturbance	6V/1s		√ (1)			
MIL-STD-1275 E Steady State, Surges and Spikes	100V/50ms, 250V/70uS, 18Vdc/500ms		√			√
MIL-STD-1275 E Starting disturbance	12V/1s		√ (1)			√ (1)
RTCA-DO-160E sect.16 cat.Z, Surges	80V/100ms, 48V/1s		√			√
DEF STAN 61-5, Part 6 28V	100V/50ms		√			√
ABD100.1.8 Surge and Normal Transients	built to meet		√			√
EN50155 Environmental	-V option	√		√	√	
EN50155, EN55022A, EN55011A, EN50121-3-2	See curves below in conduction, built to meet	√		√	√	
EN 50155 Input Range and Transient	built to meet	√		√	√	

(1) compliant with products revision 03A and further

### Electromagnetic Immunity

	Standard	Level	Value	Waveform	Source imped.	Test procedure	Mode	Criteria
Supply surge	EN50155	B	1,4 * VIN	0,1 / 1 / 0,1 s	1 Ohm	1 positive surge	OP	A
Direct transients	EN50155	D	1800V	5 / 50 μs	5 Ohms	5 pos., 5 neg.	OP	B
Surges (Common Mode Only)	EN 61000-4-5	3	2000V	1,2 / 50 μs	12 ohms		OP	B
Electrostatic discharge (to case)	EN 6100-4-2	4	8000V	1 / 50μs	330 Ohms	10 pos., 10neg.	OP	B
Electrical fast transients/burst	EN 61000-4-4	4	4000V	5 / 50μs	50 ohms		OP	B

### Immunity to Environmental Conditions

Test method	Standard	Test conditions	Status
Damp Heat	MIL STD 810E Proc. 507-2	Humidity 93 %, 40°C, 56 days	Conformal coating option only, built to meet
Shock	MIL STD 810E Proc.516.3 EN 50155	20g / 11ms 5g / 30ms	Built to meet M option M option
Vibrations	MIL STD 810E Proc. 514-3		Built to meet M option

## Electromagnetic

### Electromagnetic Emissions

EN55022B, peak detector, average and quasi-peak limit, PST14X24-48320, nominal line and power

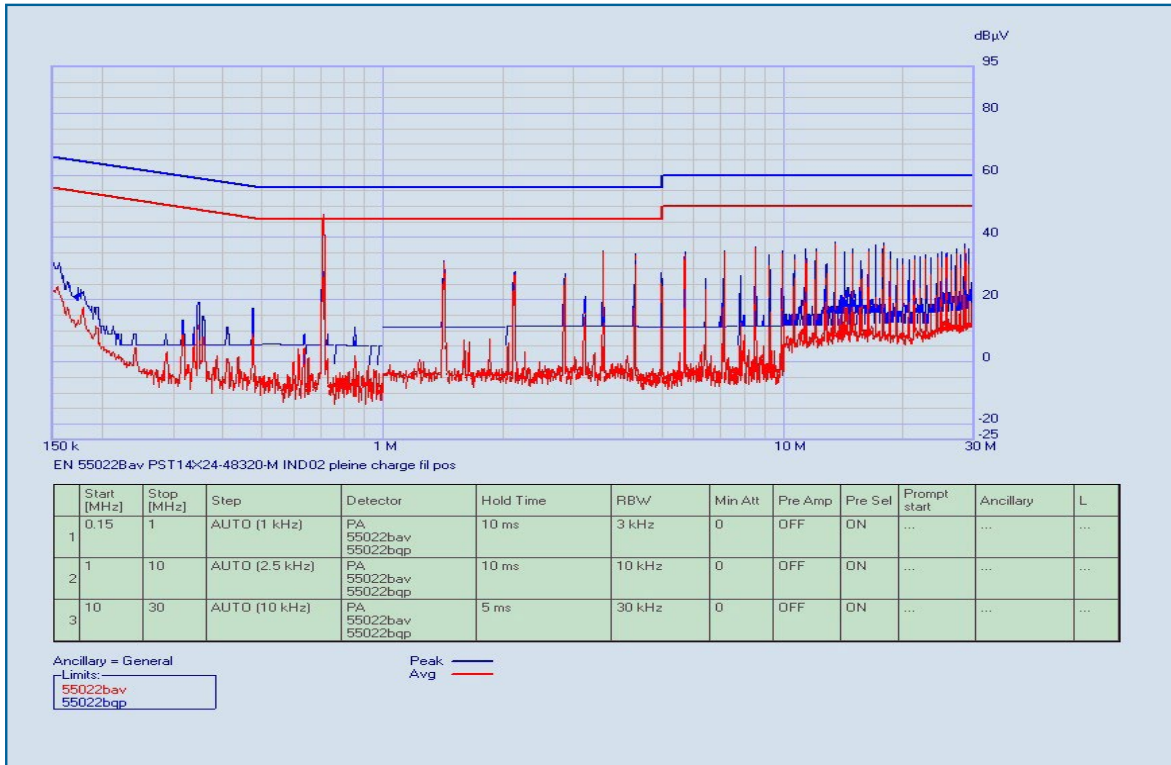

MIL STD461 CE102, peak detector, 28V limit, PST14X28-48320-MV, nominal line and power

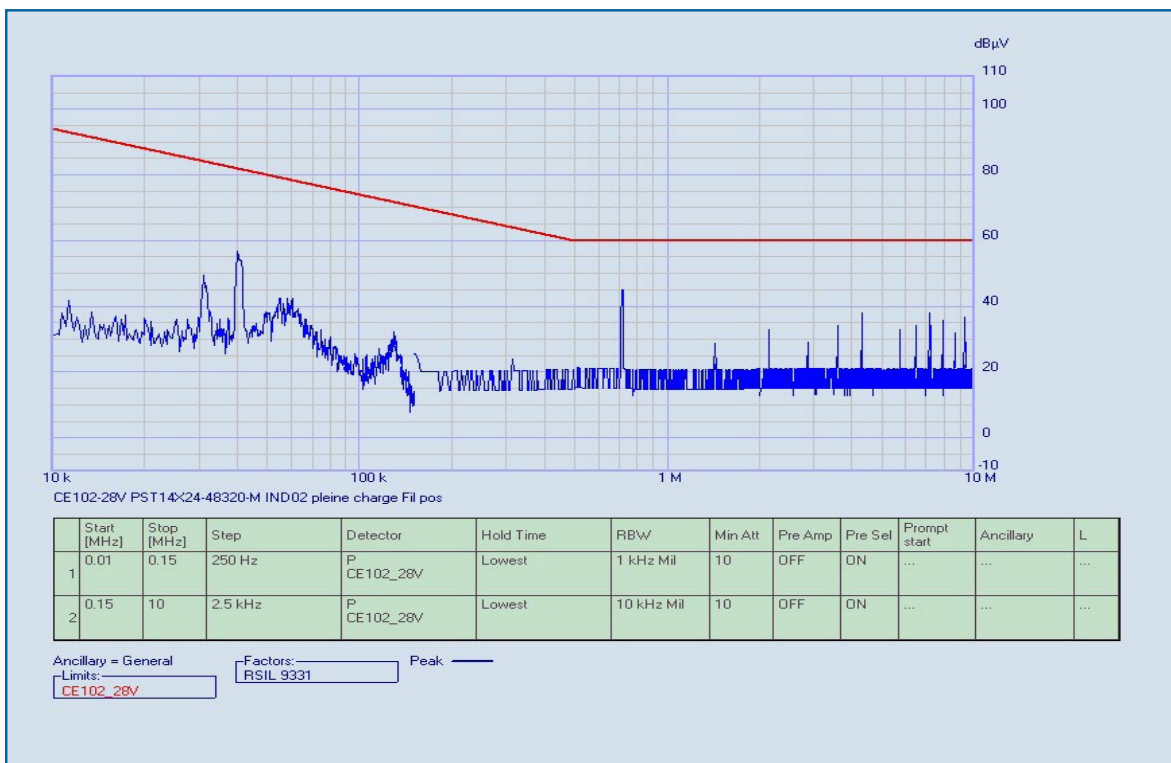

## Safety and Installations Instructions

### Connector Pin Allocation

#### Input/Output Connector

PIN	signal name	description
J11	+Vin	+Vinput
J12	-Vin	-Vinput
J1	+VOUT	+Vout
J2	-VOUT	-Vout

#### J4 : MOLEX 2 pins Picoblade 53048-0210

PIN	signal name	description
1	INH	Inhibition
2	INH RTN	Inhibition Return

#### J3 : MOLEX 5 pins Picoblade 53398-0571

PIN	signal name	description
1	PGD	Powergood Collector
2	PGD RTN	Powergood Emitter
3	+S	+ Sense
4	-S	-Sense
5	Sharing	Sharing

Before revision 5 (IND05)  
Würth P/N7461093

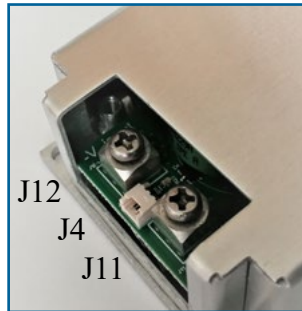

From revision 5 (IND05)  
PEM SMTSOB-M3-6ET

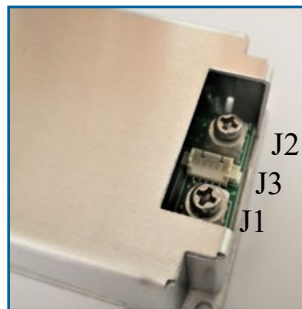
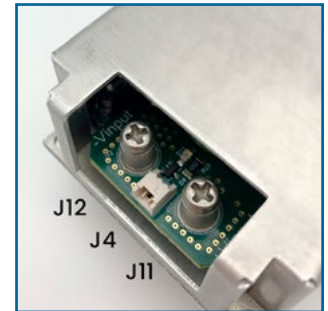

Max torque = 0,5N.m

### Electric Strength

Characteristic		Input to Chassis	Input to Output	Output to Chassis	Unit
Electric strength	Design strength	2120	2120	500	Vdc
	Factory test for production units (>10s)	2120	2120	500	Vdc
Insulation resistance (500Vdc)				> 100	Mohms

### Temperatures

Conditions		Standard			Unit
		Min.	Typ.	Max.	
Baseplate or Heatsink	Operating	-40		+100	°C
Storage	Not operating	-40		+125	

### Reliability

MIL-HDBK-217F, notice 2	Model	Heatsink Temp.	GB	GF
MTBF ( Hours)	PST14X24-28320	40°C	1709400	854700
		70°C	1006280	503140
		100°C	632291	316140

## Installations Instructions

These converters are components, intended exclusively for integration into other equipment by an industrial assembly process or by a professionally competent person. Installation must strictly follow the safety regulations in respect of the enclosure, mounting, creepage and clearance distances, markings of the end-use application.

Connection to the system shall be made via appropriate connection. The +Vin is internally fused. This fuse is designed to protect the converter against overcurrent caused by a failure, but may not be able to satisfy all requirements. External fuses in the wiring circuit to one or both input pins may be necessary to ensure compliance with local requirements.

Do not open the converters, or the warranty will be invalidated. Make sure that there is sufficient heat dissipation available for conduction cooling. This should be verified by measuring the case of temperature at the specified measuring point, when the converter is operated in the end-use application.

## Standards and Approvals

The converters are built to meet the safety standards IEC 62368-1, EN 62368-1.

'Built to meet' mentioned in the different paragraphs of the datasheet means that Power System Technology has designed the product to meet the standard but did not certify it in a laboratory.

## Accessories and assembly data

Several PST14X can be assembled together to create higher power parallel configurations or multi outputs versions. The assembly can be ordered ready to use, see chapter configuration for part numbering, or customer can create its assembly the help of the below accessories (Consult factory for technical support).

### Parallel Input bus bar PIB2 for 2up & PIB3 for 3up assemblies

CIE 14X-PIB2 and PIB3 pcb's (see below mechanical diagram) are used to interconnect the input +Vin and -Vin terminals of 2 or 3 PST14X units together. They are equipped with additional capacitors and connector for interfacing inhibition signals. The input signal cables CAB 14X-PIB connecting each PST14X to the PIB pcb have to be ordered separately.

The Pinout for inhibition connector is the same as single unit. The Input +Vin and -Vin terminals are M4 PressFit Studs from Wurth, ref. 7461111, see below pin out in the diagram.

Partnumber: CIE 14X-PIB2, article code: 7091

Partnumber: CIE 14X-PIB3, article code: 7115

Partnumber: CAB CIE14X-PIB, article code: 7158

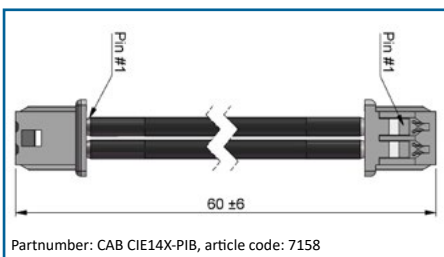

## Cleaning Agents and Process

The converters are not hermetically sealed. In order to avoid possible damage, any penetration of liquids shall be avoided.

## Railway Application

The converters have been designed observing the railway standards EN 50155 and EN 50121. All boards can be protected by a conformal coating as an option (-V).

## Isolation

The electric strength test is performed in the factory in accordance with IEC/EN 62368.

### Parallel Output bus bar POB2 for 2up & POB3 for 3up assemblies

CIE 14X-POB2 and POB3 pcb's (see below mechanical diagram) are used to interconnect the output +Vout and -Vout terminals of 2 or 3 PST14X units together. They are equipped with an active droop sharing circuit ensuring current sharing between both units and as well N+1 redundancy. Be carefull when using this accessory, each unit must be individually accurately trimmed at the required voltage (+50mV), at 50% of its load. The output drop voltage of the complete assembly at full load will depend on the output voltage version. Adding the accessories cables CAB CIE14X-POB will interconnect the Power Good signals. The Output +Vout and -Vout terminals are M4 PressFit Studs from Wurth, ref. 7461111, see below pin out in the diagram.

Partnumber: CIE 14X-POB2, article code: 7185

Partnumber: CIE 14X-POB3, article code: 7464

Partnumber: CAB CIE14X-POB, article code: 7283

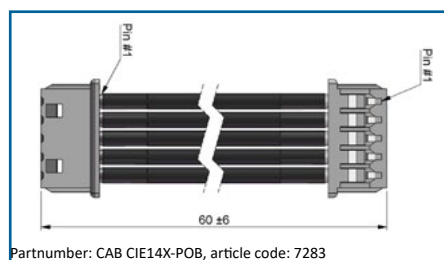

Two PST14X in parallel operation

**Note:** PINOUT of signals for CIE 14X-PIB is same as J4 of individual unit. PINOUT of CIE 14X-POB (Picoblade 530480210 Pin1 PGD, Pin2 PGD RTN)

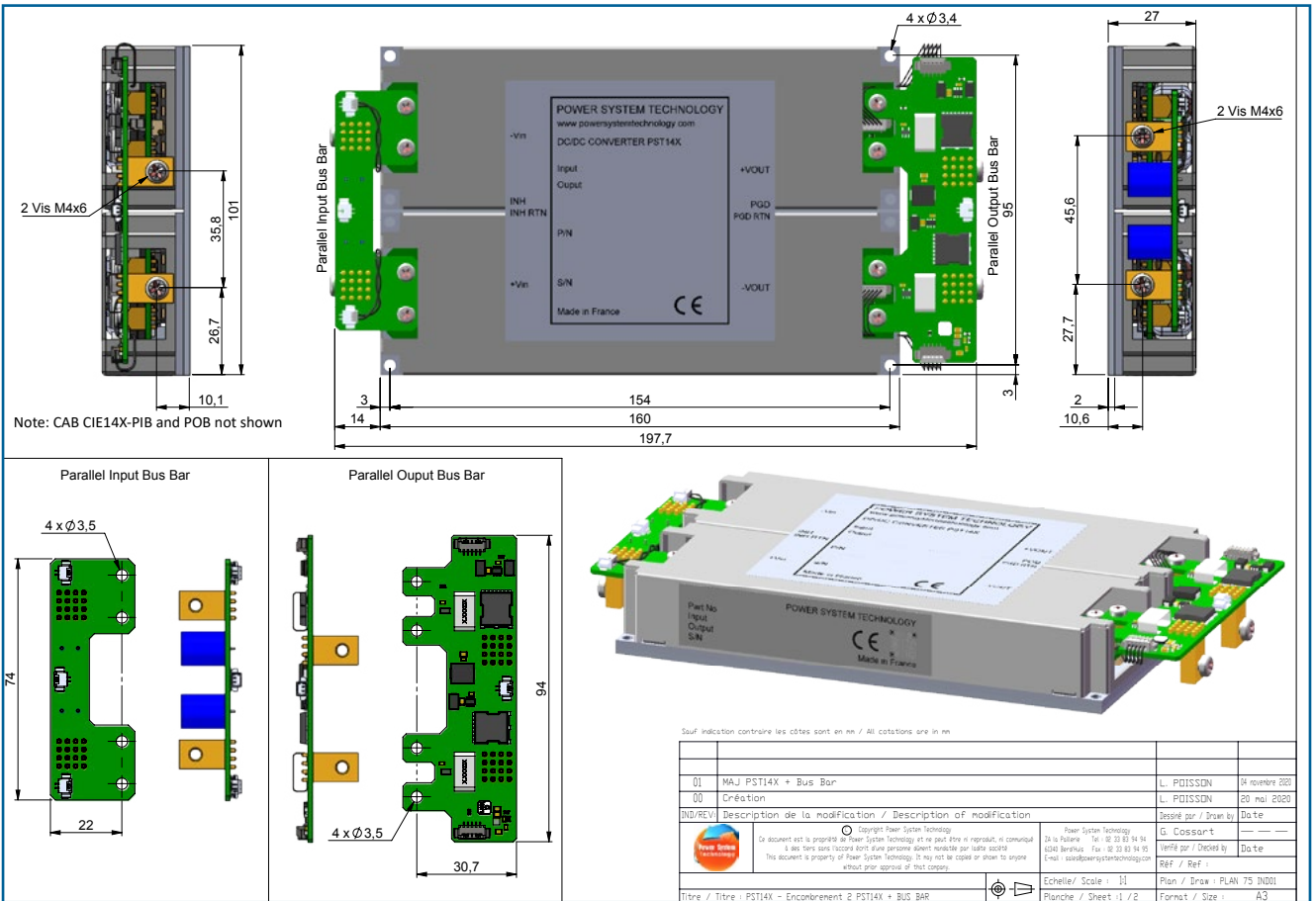

Technical drawing showing two PST14X units in parallel operation. The main unit is a DC/DC CONVERTER PST14X with labels: -Vin, Input, Output, INH, INH RTN, P/N, +Vin, S/N, +VOUT, PGD, PGD RTN, -VOUT. Dimensions include 101, 35.8, 26.7, 10.1, 154, 160, 197.7, 95, 27, 45.6, 27.7, 10.6, 2, 3, 14, 4 x Ø3.4, and 2 Vis M4x6.

Note: CAB CIE14X-PIB and POB not shown

Parallel Input Bus Bar: 4 x Ø3.5, 74, 22

Parallel Output Bus Bar: 4 x Ø3.5, 94, 30.7

3D rendering of the PST14X unit with labels: Part No, Input, Output, S/N, POWER SYSTEM TECHNOLOGY, CE, Made in France.

Sauf indication contraire les cotes sont en mm / All cotations are in mm

01	MAJ PST14X + Bus Bar	L. POISSON	14 novembre 2020
00	Création	L. POISSON	20 mai 2020
MD/REV	Description de la modification / Description of modification	Dessiné par / Drawn by	Date
	<p>Copyright: Power System Technology                  Ce document est la propriété de Power System Technology et ne peut être ni reproduit, ni communiqué à des tiers sans l'accord écrit d'une personne dûment mandatée par l'auteur(s).                  This document is property of Power System Technology. It may not be copied or disseminated without prior approval of this company.</p> <p>Power System Technology                  43440 Benerville, France - Tel: 02 33 33 34 34                  Email: econtact@powersystemtechnology.com</p>	G. COSSANT	---
		Vérifié par / Checked by	Date
		Réf / Ref	
Titre / Title: PST14X - Encadrement 2 PST14X + BUS BAR		Echelle / Scale: 1:1	Plan / Draw: PLAN 75 IN001
		Planche / Sheet: 1 / 2	Format / Size: A3

## IP assembly

When application requires sealed package while keeping conduction or convection, the IP65 packaging can be used integrating one or several PST4X (-IP option). See options and configuration chapter for partnumbering. Heatsink options (-H or -H1) can be added to the IP package (height to be increased by 15mm).

### One PST14X assembly with -IP option

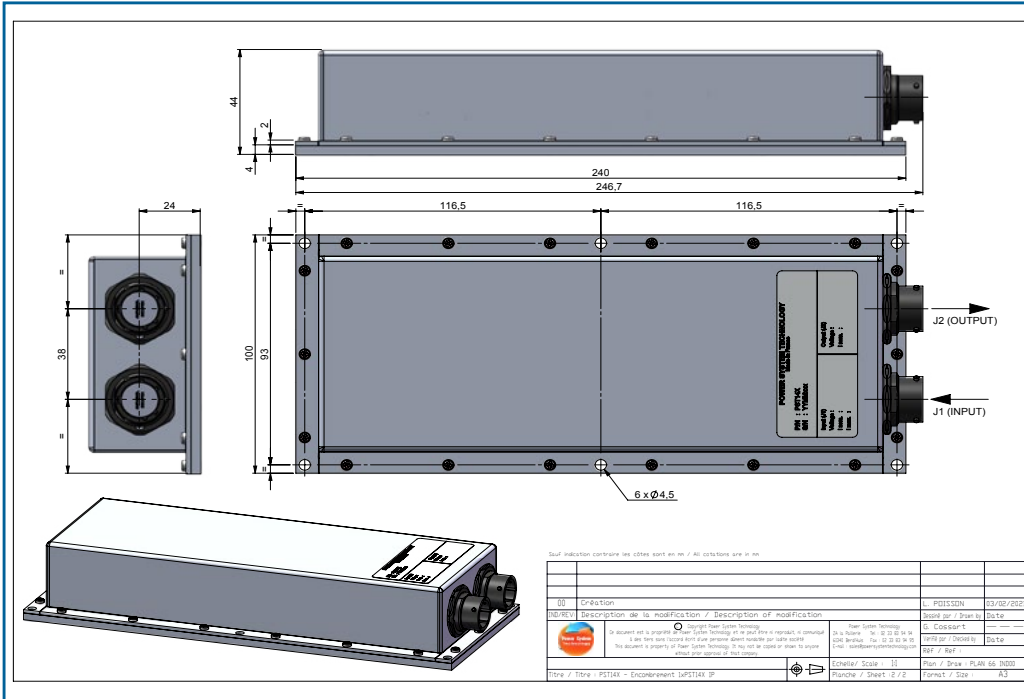

J1 INPUT 1xPST14X – Option IP (20A max)		
Type	PIN	Description
	A	+Vinput
	B	
	C	
	D	
	E	-Vinput
	F	
	G	
	H	
I	INH	
J	INH RTN	
AMPHENOL Male 451-07A128P50 033K		
J2 OUTPUT 1xPST14X – Option IP (36A max)		
Type	PIN	Description
	A	+Vout
	B	
	C	
	D	
	E	-Vout
	F	
	G	
	H	
	I	PGD
	J	PGD RTN
	K	
	L	
	M	
	N	
	O	
	P	
AMPHENOL Female 451-07A1214S50 033K		

### Two PST14X assembly with -IP option

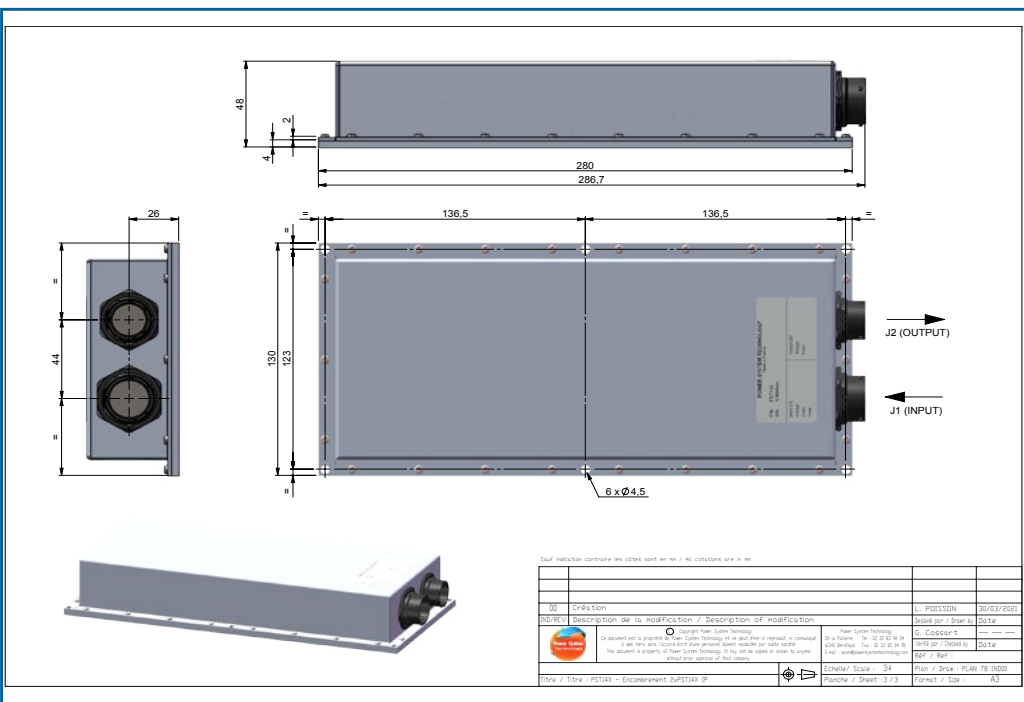

J1 INPUT 2xPST14X – Option IP (40A max)		
Type	PIN	Description
	A	+Vin
	B	
	C	
	D	
	E	-Vin
	F	
	G	
	H	
I	INH	
J	INH RTN	
AMPHENOL Male 451-07A168P50 033K		
J2 1xOUTPUT 2xPST14X – (45A max)		
Type	PIN	Description
	A	+Vout
	B	
	C	
	D	
	E	-Vout
	F	
	G	
	H	
	I	
	J	
	K	
	L	
	M	
	N	
	O	
	P	
Q		
R		
S		
T		
U	PGD	
V	PGD RTN	
AMPHENOL Female 451-07A1419S50 033K		
J2 2xOUTPUTS 2xPST14X – (22A max)		
Type	PIN	Description
	A	+Vout1
	B	
	C	
	D	
	E	+Vout2
	F	
	G	
	H	
	I	-Vout1
	J	
	K	
	L	
	M	-Vout2
	N	
	O	
	P	
Q		
R		
S		
T		
U	PGD1 RTN	
V	PGD2 RTN	
AMPHENOL Female 451-07A1419S50 033K		

## Mechanical data

Dimension: 50 x 160 x 25mm (50 x 160 x 40mm if -H or H1)  
Weight : 0,260Kg

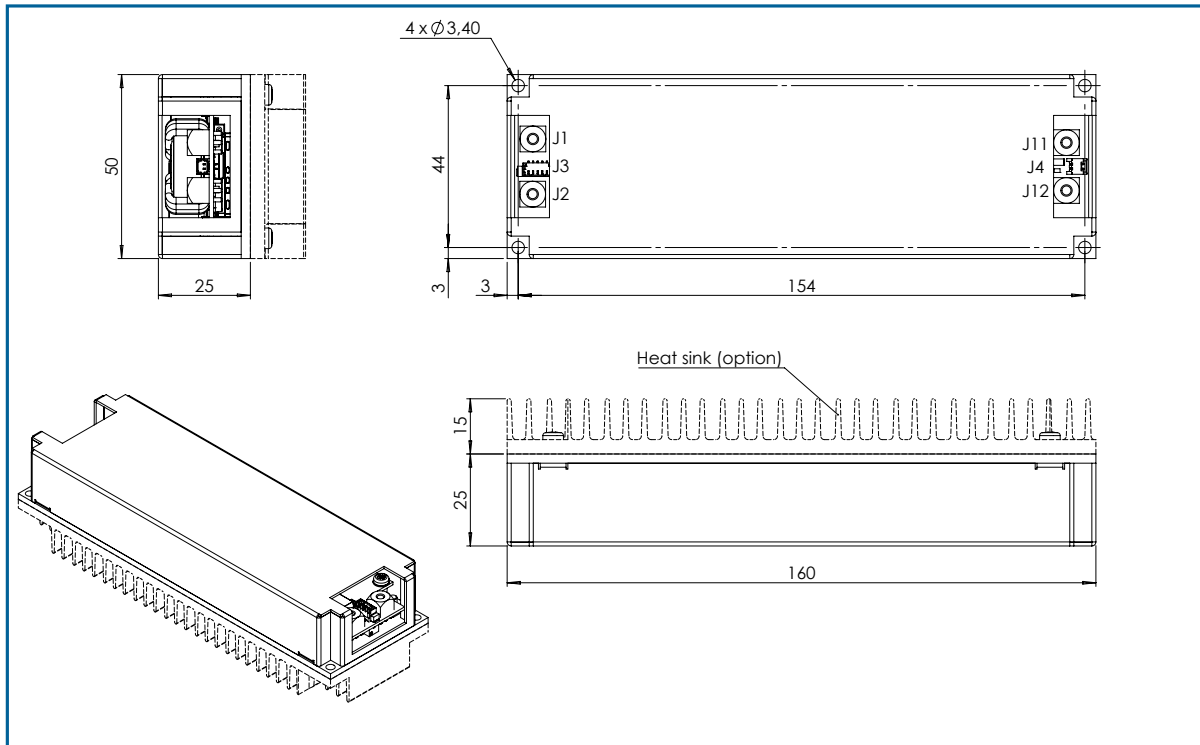

## Options and configurations

For Input and Output configurations see page 3.

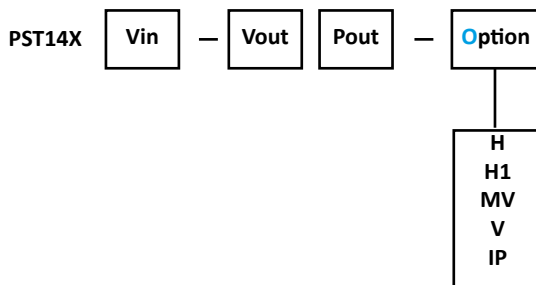

For multiple combination of the **same package and get units already delivered** with accessories mounted (Bus bar for parallel, common baseplate), please consult factory to get Partnumber and pricing. As example, The P/N will be as follows:

### Example :

2up 2 outputs (see page 3 for V1P1 & V2P2)

PST14X Vin-V1P1-V2P2-O

2up 1 output

PST14X Vin-V1P-O

1 output of P1+P2 where P1=P2  
(do not put in parallel 2 different power)

3up 3 outputs

PST14X Vin -V1P1-V2P2-V3P3-O

3up 2 outputs

PST14X Vin -V1P-V2P2-O  
PST14X Vin -V1P1-V2P-O

(P = 2 x P1)